

EANCOM 2002 Syntax 3
Edition 2016_Update 2021

Application error and acknowledgement message
(APERAK)

Introduction.....	2
Branching Diagram	4
Message Structure.....	6
Segmentlayout.....	7
Codes	26
Example.....	113

Einführung

Introduction

The following message specification is based on the publication of the "Application Error and Acknowledgement Message" of GS1 Global in syntax 3.

Status

MESSAGE TYPE: APERAK
REFERENCE DIRECTORY: D.01B
EANCOM® SUBSET VERSION: 004

Definition

A message from the party who received an original message, to the party who issued the original message, to acknowledge to the message issuer the receipt of the original message by the recipient's application and to acknowledge errors made during the processing within the application.

Principles

A message which is first processed at translator level to detect syntax errors and to acknowledge its receipt (CONTRL) is then transmitted to the receiving application to be processed. Upon reaching this state the receiving application may issue an acknowledgement confirming receipt of the message by the application.

The picture below shows the difference between the CONTRL message and APERAK:

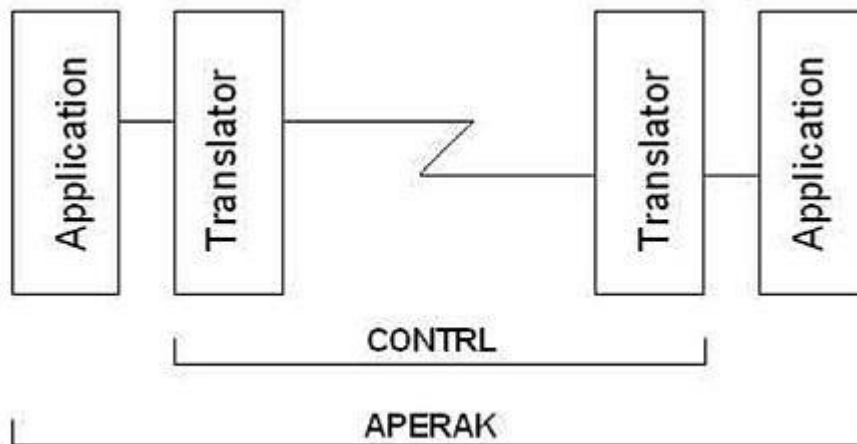

The APERAK message should be generated by the application software NOT by an EDI-translator software.

The APERAK message must NOT be used to acknowledge the receipt of an interchange.

Parties as stated in the message which is being acknowledged, must be mentioned in the APERAK. Such parties are not the sender and the receiver identified at the interchange level.

Einführung

Within one APERAK message it is NOT possible to acknowledge the receipt of more than one message.

Example with an INVOIC message:

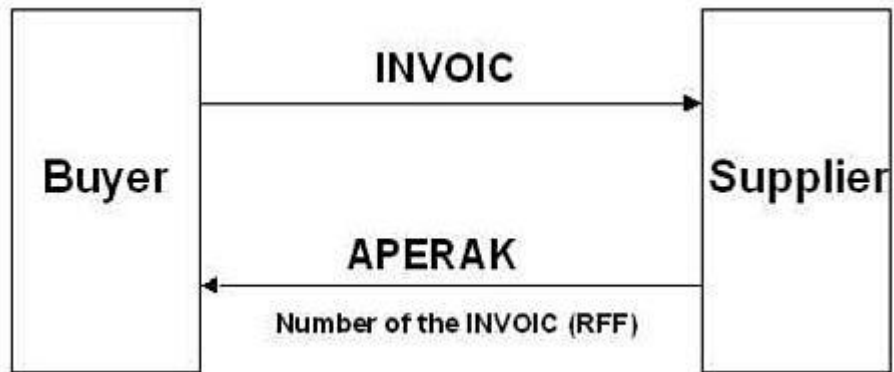

Branching Diagram

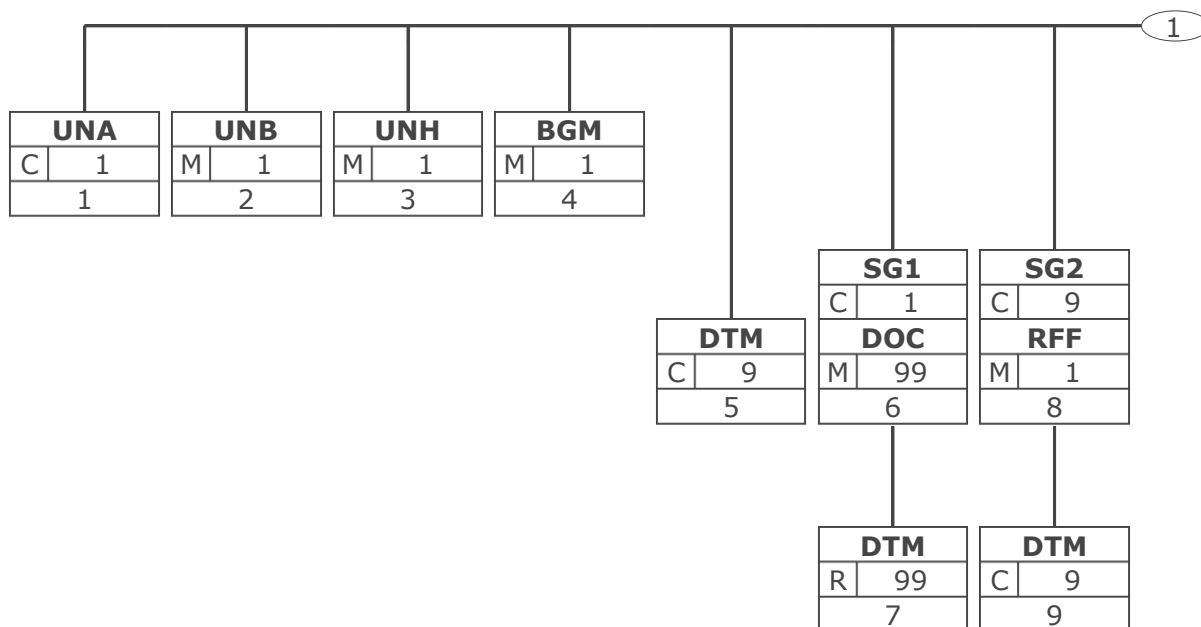

Tag	Tag = Segment/Group Tag
St MaxOcc	St = Status (M=Mandatory, C=Conditional, R=Required, O=Optional, A=Advised, D=Dependent)
No	MaxOcc = Maximum occurrence of the segment/group; No = Consecutive segment number

Branching Diagram

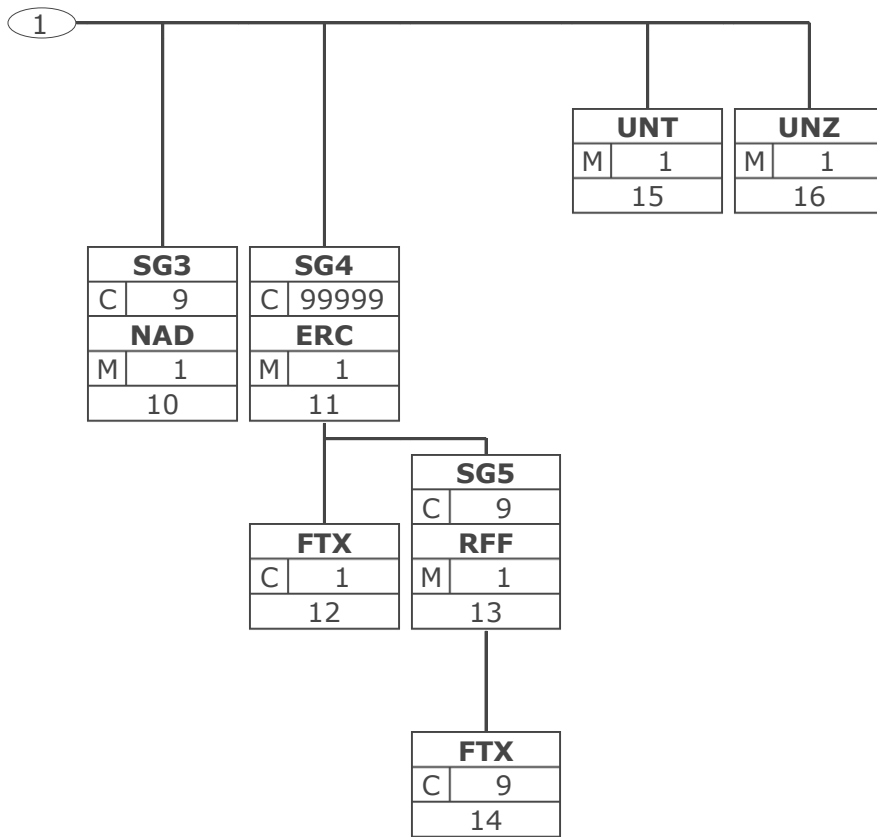

Tag	Tag = Segment/Group Tag
St MaxOcc	St = Status (M=Mandatory, C=Conditional, R=Required, O=Optional, A=Advised, D=Dependent)
No	MaxOcc = Maximum occurrence of the segment/group; No = Consecutive segment number

Message Structure

Seg.	No.	Status	Max Occ	Segment
UNA	1	C	1	Service string advice
UNB	2	M	1	Interchange header
Application error and acknowledgement message Heading Section				
UNH	3	M	1	Message header
BGM	4	M	1	Beginning of message
DTM	5	C	9	Date/time/period
SG1		C	1	DOC-DTM
DOC	6	M	99	Document/message details
DTM	7	R	99	Date/time/period
SG2		C	9	RFF-DTM
RFF	8	M	1	Reference
DTM	9	C	9	Date/time/period
SG3		C	9	NAD
NAD	10	M	1	Name and address
Application error and acknowledgement message Detail Section				
SG4		C	99999	ERC-FTX-SG5
ERC	11	M	1	Application error information
FTX	12	C	1	Free text
SG5		C	9	RFF-FTX
RFF	13	M	1	Reference
FTX	14	C	9	Free text
Application error and acknowledgement message Summary Section				
UNT	15	M	1	Message trailer
UNZ	16	M	1	Interchange trailer

Max. Occ. = Maximum occurrence of the segment/group, Status: M=Mandatory, C=Conditional, R=Required, O=Optional, A=Advised, D=Dependent

Segment Layout

No. Seg	St	Max. Occ.				
1	UNA	C 1	Service string advice To define the characters selected for use as delimiters and indicators in the rest of the interchange that follows.			
Business Term	DE	EDIFACT	Format	St	*	Description
	UNA1	Component data element separator	an1	M	*	Used as a separator between component data elements contained within a composite data element (default value: ":")
	UNA2	Data element separator	an1	M	*	Used to separate two simple or composite data elements (default value: "+")
	UNA3	Decimal notation	an1	M	*	Used to indicate the character used for decimal notation (default value: ".")
	UNA4	Release indicator	an1	M	*	Used to restore any service character to its original specification (value: "?").
	UNA5	Reserved for future use	an1	M	*	(default value: space)
	UNA6	Segment terminator	an1	M	*	Used to indicate the end of segment data (default value: "'")
<p>The service string advice shall begin with the upper case characters UNA immediately followed by six characters in the order shown below. The same character shall not be used in more than one position of the UNA.</p> <p>This segment is used to inform the receiver of the interchange that a set of service string characters which are different to the default characters are being used.</p> <p>When using the default set of service characters, the UNA segment need not be sent. If it is sent, it must immediately precede the UNB segment and contain the four service string characters (positions UNA1, UNA2, UNA4 and UNA6) selected by the interchange sender.</p> <p>Regardless of whether or not all of the service string characters are being changed every data element within this segment must be filled, (i.e., if some default values are being used with user defined ones, both the default and user defined values must be specified).</p> <p>When expressing the service string characters in the UNA segment, it is not necessary to include any element separators.</p> <p>The use of the UNA segment is required when using a character set other than level A.</p> <p>Example: UNA:+.?' '</p> <p>Example: UNA:+.?' '</p>						

Max. Occ. = Maximum Occurrence, St = Status, * = Restricted Codes

Status: M=Mandatory, R=Required, O=Optional, C=Conditional, D=Dependent, A=Advised, N=Not used

Segment Layout

No. Seg	St	Max. Occ.			
2	UNB	M 1	Interchange header To start, identify and specify an interchange.		
Business Term	DE	EDIFACT	Format	St	* Description
	S001	Syntax identifier		M	See Part I chapter 5.2.7 and segment notes.
	0001	Syntax identifier	a4	M	* UNOA UN/ECE level A UNOB UN/ECE level B UNOC UN/ECE level C UNOD UN/ECE level D UNOE UN/ECE level E UNOF UN/ECE level F
	0002	Syntax version number	n1	M	* 3 Version 3
	S002	Interchange sender		M	
	0004	Sender identification	an..35	M	GLN (n13)
	0007	Partner identification code qualifier	an..4	R	* 14 GS1
	0008	Address for reverse routing	an..14	O	
	S003	Interchange recipient		M	
	0010	Recipient identification	an..35	M	GLN (n13)
	0007	Partner identification code qualifier	an..4	R	* 14 GS1
	0014	Routing address	an..14	O	
	S004	Date/time of preparation		M	
	0017	Date of preparation	n6	M	YYMMDD
	0019	Time of preparation	n4	M	HHMM
	0020	Interchange control reference	an..14	M	Unique reference identifying the interchange. Created by the interchange sender.
	S005	Recipient's reference, password		O	
	0022	Recipient's reference/ password	an..14	M	
	0025	Recipient's reference/ password qualifier	an2	O	
	0026	Application reference	an..14	O	Message identification if the interchange contains only one type of message.
	0029	Processing priority code	a1	O	A Highest priority
	0031	Acknowledgement request	n1	O	1 Requested
	0032	Communications agreement ID	an..35	O	* EANCOM.....
	0035	Test indicator	n1	O	1 Interchange is a test

Max. Occ. = Maximum Occurrence, St = Status, * = Restricted Codes

Status: M=Mandatory, R=Required, O=Optional, C=Conditional, D=Dependent, A=Advised, N=Not used

Segment Layout

This segment is used to envelope the interchange, as well as to identify both, the party to whom the interchange is sent and the party who has sent the interchange. The principle of the UNB segment is the same as a physical envelope which covers one or more letters or documents, and which details, both the address where delivery is to take place and the address from where the envelope has come.

S001: The character encoding specified in basic code table of ISO/IEC 646 (7-bit coded character set for information interchange) shall be used for the interchange service string advice (if used) and up to and including the composite data element S001 'Syntax identifier' in the interchange header. The character repertoire used for the characters in an interchange shall be identified from the code value of data element 0001 in S001 'Syntax identifier' in the interchange header. The character repertoire identified does not apply to objects and/or encrypted data.

The default encoding technique for a particular repertoire shall be the encoding technique defined by its associated character set specification.

DE 0001: The recommended (default) character set for use in EANCOM® for international exchanges is character set A (UNOA). Should users wish to use character sets other than A, an agreement on which set to use should be reached on a bilateral basis before communications begin.

DE 0004, 0008, 0010, 0014, 0042 and 0046: Within EANCOM® the use of the Global Location Number (GLN) is recommended for the identification of the interchange sender and recipient.

DE 0008: Identification (e.g. a division) specified by the sender of the interchange, to be included if agreed, by the recipient in response interchanges, to facilitate internal routing.

DE 0042: Sub-level of sender internal identification, when further sub-level identification is required.

DE 0014: The address for routing, provided beforehand by the interchange recipient, is used by the interchange sender to inform the recipient of the internal address, within the latter's systems, to which the interchange should be routed. It is recommended that the GLN be used for this purpose.

DE 0007: Identification (e.g. a division) specified by the recipient of the interchange, to be included if agreed, by the sender in response interchanges, to facilitate internal routing.

DE 0046: Sub-level of recipient internal identification, when further sub-level identification is required.

DE S004: The date and time specified in this composite should be the date and time at which the interchange sender prepared the interchange. This date and time may not necessarily be the same as the date and time of contained messages.

DE 0020: The interchange control reference number is generated by the interchange sender and is used to identify uniquely each interchange. Should the interchange sender wish to re-use interchange control reference numbers, it is recommended that each number be preserved for at least a period of three months before being re-used. In order to guarantee uniqueness, the interchange control reference number should always be linked to the interchange sender's identification (DE 0004).

DE S005: The use of passwords must first be agreed bilaterally by the parties exchanging the interchange.

DE 0026: This data element is used to identify the application, on the interchange recipient's system, to which the interchange is directed. This data element may only be used if the interchange contains only one type of message, (e.g. only invoices). The reference used in this data element is assigned by the interchange sender.

DE 0031: This data element is used to indicate whether an acknowledgement to the interchange is required. The EANCOM® APERAK or CONTRL message should be used to provide acknowledgement of interchange receipt. In addition, the EANCOM® CONTRL message may be used to indicate when an interchange has been rejected due to syntax errors.

DE 0032: This data element is used to identify any underlying agreements which control the exchange of data. Within EANCOM®, the identity of such agreements must start with the letters 'EANCOM', the remaining characters within the data element being filled according to bilateral

Max. Occ. = Maximum Occurrence, St = Status, * = Restricted Codes

Status: M=Mandatory, R=Required, O=Optional, C=Conditional, D=Dependent, A=Advised, N=Not used

Segment Layout

agreements.

Example: UNB+UNOA:3+4012345000009:14:1+4000004000002:14:4000004000099+021013:1043+12345555+
REF:AA++A+1+EANCOM-DISI+1'

Example: UNB+UNOA:3+5412345678908:14+8798765432106:14+020102:1000+12345555++++EANCOMREF
52'

Max. Occ. = Maximum Occurrence, St = Status, * = Restricted Codes

Status: M=Mandatory, R=Required, O=Optional, C=Conditional, D=Dependent, A=Advised, N=Not used

Segment Layout

No. Seg	St	Max. Occ.				
3	UNH	M 1	Message header			To head, identify and specify a message.
Business Term	DE	EDIFACT	Format	St	*	Description
	0062	Message reference number	an..14	M		Senders unique message reference. Sequence number of messages in the interchange. DE 0062 in UNT will have the same value. Generated by the sender.
	S009	Message identifier		M		
	0065	Message type	an..6	M	*	APERAK Application error and acknowledgement message
	0052	Message version number	an..3	M	*	D Draft version/ UN/EDIFACT Directory
	0054	Message release number	an..3	M	*	01B Release 2001 - B
	0051	Controlling agency	an..2	M	*	UN UN/CEFACT
	0057	Association assigned code	an..6	R	*	EAN004 GS1 version control number (GS1 Permanent Code)
<p>This segment is used to head, identify and specify a message. DE's 0065, 0052, 0054 and 0051: Indicate that the message is a UNSM Application Error and Acknowledgement message based on the D.01B directory under the control of the United Nations. Example: Example: UNH+ME000001+APERAK:D:01B:UN:EAN004' Example: UNH+ME000001+APERAK:D:01B:UN:EAN004'</p>						

Max. Occ. = Maximum Occurrence, St = Status, * = Restricted Codes
 Status: M=Mandatory, R=Required, O=Optional, C=Conditional, D=Dependent, A=Advised, N=Not used

Segment Layout

No. Seg	St	Max. Occ.				
4	BGM	M 1	Beginning of message To indicate the type and function of a message and to transmit the identifying number.			
Business Term	DE	EDIFACT	Format	St	*	Description
	C002	Document/message name		R		
	1001	Document name code	an..3	R	*	305 Application error and acknowledgement
	C106	Document/message identification		R		
	1004	Document identifier	an..35	R		Number of the APERAK message assigned by document sender.
	1225	Message function code	an..3	R	*	6 Confirmation 9 Original 23 Transaction on hold 27 Not accepted
<p>This segment is used to indicate the type and function of a message and to transmit the identifying number. Example: Example: BGM+305+X+6 ' Example: BGM+305+100001+6 '</p>						

Max. Occ. = Maximum Occurrence, St = Status, * = Restricted Codes
Status: M=Mandatory, R=Required, O=Optional, C=Conditional, D=Dependent, A=Advised, N=Not used

Segment Layout

No.	Seg	St	Max.	Occ.			
5	DTM	C	9		Date/time/period To specify date, and/or time, or period.		
Business Term	DE	EDIFACT	Format	St	*	Description	
	C507	Date/time/period		M			
	2005	Date or time or period function code qualifier	an..3	M	*	137 Document/ message date/ time	
	2380	Date or time or period value	an..35	R			
	2379	Date or time or period format code	an..3	R		102 CCYYMMDD 203 CCYYMMDDHHMM	
<p>This segment is used to specify the date of the message. DE 2005: Identification of the 'Document/message date/time' (code value 137) is mandatory in an EANCOM message. Example: The Application Error and Acknowledgement message was created at 12 o'clock on the 30th of August 2002. Example: DTM+137:200208301200:203 ' Example: DTM+137:200208301200:203 '</p>							

Max. Occ. = Maximum Occurrence, St = Status, * = Restricted Codes
 Status: M=Mandatory, R=Required, O=Optional, C=Conditional, D=Dependent, A=Advised, N=Not used

Segment Layout

No. Seg	St	Max. Occ.				
SG1	C	1	DOC-DTM			
A segment group to provide information on the document being acknowledged.						
6						
DOC	M	99	Document/message details			
To identify documents and details directly related to it.						
Business Term	DE	EDIFACT	Format	St	*	Description
	C002	Document/message name		R		
	1001	Document name code	an..3	R		220 Order 351 Despatch advice 261 Self billed credit note 380 Commercial invoice 381 Credit note - goods and services 389 Self-billed invoice
	1131	Code list identification code	an..17	N		
	3055	Code list responsible agency code	an..3	O		
	C503	Document/message details		R		
	1004	Document identifier	an..35	R		
	1373	Document status code	an..3	O		1 Accepted 3 Conditionally accepted 8 Rejected 10 Document currently valid 39 On hold
To identify documents and details directly related to it.						
Example:						
The referenced document is an invoice with the number 4726354. It has been accepted.						
The referenced document is an invoice with the number 9226354. It has been rejected.						
Example: DOC+380::6+4726354:1'						
Example: DOC+380+4726354:1'						
Example: DOC+380+9226354:8'						

Max. Occ. = Maximum Occurrence, St = Status, * = Restricted Codes
 Status: M=Mandatory, R=Required, O=Optional, C=Conditional, D=Dependent, A=Advised, N=Not used

Segment Layout

No.	Seg	St	Max. Occ.			
7	SG1	C	1	DOC-DTM		
	A segment group to provide information on the document being acknowledged.					
	DTM	R	99	Date/time/period		
To specify date, and/or time, or period.						
Business Term	DE	EDIFACT	Format	St	*	Description
	C507	Date/time/period		R		
	2005	Date or time or period function code qualifier	an..3	R	*	137 Document/ message date/ time
	2380	Date or time or period value	an..35	R		
	2379	Date or time or period format code	an..3	R		102 CCYYMMDD
To specify date, and/or time, or period.						
Example: DTM+137:20160827:102'						

Max. Occ. = Maximum Occurrence, St = Status, * = Restricted Codes
 Status: M=Mandatory, R=Required, O=Optional, C=Conditional, D=Dependent, A=Advised, N=Not used

Segment Layout

No.	Seg	St	Max. Occ.			
	SG2	C	9	RFF-DTM		
	A group of segments to specify the document/message to which the current message relates, and related date and time.					
8	RFF	M	1	Reference		
	To specify a reference.					
Business Term	DE	EDIFACT	Format	St	*	Description
	C506	Reference		M		
	1153	Reference code qualifier	an..3	M		AAN Delivery schedule number APQ Commercial account summary reference number AGG Dispute number IV Invoice number ON Order number (buyer)
	1154	Reference identifier	an..70	R		This number is the same number as in the BGM segment (DE 1004) of the message which is being acknowledged.
<p>This segment is used to specify reference numbers related to the message which is being acknowledged.</p> <p>Example: The message being acknowledged is an order.</p> <p>Example: RFF+ON:154245' Example: RFF+ON:100001'</p>						

Max. Occ. = Maximum Occurrence, St = Status, * = Restricted Codes
Status: M=Mandatory, R=Required, O=Optional, C=Conditional, D=Dependent, A=Advised, N=Not used

Segment Layout

No. Seg	St	Max. Occ.				
SG2	C	9	RFF-DTM			
A group of segments to specify the document/message to which the current message relates, and related date and time.						
9			DTM	C	9	Date/time/period
To specify date, and/or time, or period.						
Business Term	DE	EDIFACT	Format	St	*	Description
	C507	Date/time/period		M		
	2005	Date or time or period function code qualifier	an..3	M	*	171 Reference date/time
	2380	Date or time or period value	an..35	R		The date/time indicated here is the same as the date/time in the DTM segment under BGM used with qualifier 137 of the message which is being acknowledged.
	2379	Date or time or period format code	an..3	R		102 CCYYMMDD 203 CCYYMMDDHHMM
This segment is used to specify dates or periods relating to the previous RFF segment. Example: Example: DTM+171:19970730:102' Example: DTM+171:200208251000:203'						

Max. Occ. = Maximum Occurrence, St = Status, * = Restricted Codes
Status: M=Mandatory, R=Required, O=Optional, C=Conditional, D=Dependent, A=Advised, N=Not used

Segment Layout

No. Seg	St	Max. Occ.			
SG3	C	9	NAD		
10			A group of segments to specify the identifications of message sender and message receiver.		
NAD	M	1	Name and address		
			To specify the name/address and their related function, either by C082 only and/or unstructured by C058 or structured by C080 thru 3207.		
Business Term	DE	EDIFACT	Format	St	* Description
	3035	Party function code qualifier	an..3	M	BY Buyer SU Supplier
	C082	Party identification details		A	
	3039	Party identifier	an..35	M	
	1131	Code list identification code	an..17	N	
	3055	Code list responsible agency code	an..3	R	* 9 GS1
	C058	Name and address		O	This composite may only be used to fulfill the requirements of directive 2003/58/EC, article 4.
	3124	Name and address description	an..35	M	
	3124	Name and address description	an..35	O	
	3124	Name and address description	an..35	O	
	3124	Name and address description	an..35	O	
	3124	Name and address description	an..35	O	
	C080	Party name		D	
	3036	Party name	an..35	M	Party Name in clear text.
	3036	Party name	an..35	O	
	3036	Party name	an..35	O	
	3036	Party name	an..35	O	
	3036	Party name	an..35	O	
	3045	Party name format code	an..3	O	
	C059	Street		D	
	3042	Street and number or post office box identifier	an..35	M	Building Name/Number and Street
	3042	Street and number or post office box identifier	an..35	O	Name and/or P.O. Box.
	3042	Street and number or post office box identifier	an..35	O	

Max. Occ. = Maximum Occurrence, St = Status, * = Restricted Codes
 Status: M=Mandatory, R=Required, O=Optional, C=Conditional, D=Dependent, A=Advised, N=Not used

Segment Layout

Business Term	DE	EDIFACT	Format	St	*	Description
	3042	Street and number or post office box identifier	an..35	O		
	3164	City name	an..35	D		City/Town name, clear text
	C819	Country sub-entity details		D		
	3229	Country sub-entity name code	an..9	O		
	1131	Code list identification code	an..17	O		
	3055	Code list responsible agency code	an..3	O		
	3228	Country sub-entity name	an..70	O		County/State, clear text.
	3251	Postal identification code	an..17	D		Postal Code
	3207	Country name code	an..3	D		ISO 3166 two alpha code

This segment is used to identify the parties who exchanged the message which is being acknowledged.

Example:

Dependency Notes:

The following composites and data elements are only used when a coded name and address can not be used. The affected composites and data elements are as follows:

C080 - C059 - 3164 - C819 - 3251 - 3207

Example: NAD+SU+1::9+X:X:::X+X:X:X:X:X:1+X:X:X:X+X:23:2:X+X+AD'

Example: NAD+BY+5412345000013::9'

Example: NAD+SU+4012345500004::9'

Segment Layout

No. Seg	St	Max. Occ.				
SG4	C	99999	ERC-FTX-SG5			
A group of segments to identify the application error(s) within a specified received message and to give specific details related to the error type or to precise the type of acknowledgement.						
11	ERC	M 1	Application error information			
To identify the type of application error within a message.						
Business Term	DE	EDIFACT	Format	St	*	Description
	C901	Application error detail		M		Should it not be possible to provide a user code in this data element and a free form characteristic description is used in data element 9321, then it is recommended that the code value 'ZZZ' be put in data element 1131.
	9321	Application error code	an..8	M		
	1131	Code list identification code	an..17	O		ZZZ Mutually defined
	3055	Code list responsible agency code	an..3	D		91 Assigned by supplier or supplier's agent 92 Assigned by buyer or buyer's agent
<p>This segment is used to identify the type of application error in the previously sent message.</p> <p>Example: The receiver did not get any dates in the application.</p> <p>Example: ERC+X:23:91' Example: ERC+NODAT:::91'</p>						

Max. Occ. = Maximum Occurrence, St = Status, * = Restricted Codes
Status: M=Mandatory, R=Required, O=Optional, C=Conditional, D=Dependent, A=Advised, N=Not used

Segment Layout

No. Seg	St	Max. Occ.			
SG4	C	99999	ERC-FTX-SG5		
A group of segments to identify the application error(s) within a specified received message and to give specific details related to the error type or to precise the type of acknowledgement.					
12	FTX	C 1	Free text		
To provide free form or coded text information.					
Business Term	DE	EDIFACT	Format	St	* Description
	4451	Text subject code qualifier	an..3	M	AAO Error description (free text)
	4453	Free text function code	an..3	O	1 Text for subsequent use 3 Text for immediate use
	C107	Text reference		D	This composite is only used when trading partners have agreed to use mutually defined code values.
	4441	Free text value code	an..17	M	
	1131	Code list identification code	an..17	O	
	3055	Code list responsible agency code	an..3	D	86 Assigned by party originating the message
	C108	Text literal		D	This composite is only used if coded text can not be used.
	4440	Free text value	an..51	M	
	4440	Free text value	an..51	O	
	4440	Free text value	an..51	O	
	4440	Free text value	an..51	O	
	4440	Free text value	an..51	O	
	3453	Language name code	an..3	D	This data element is only used when non coded free text has been provided in data element C108.
<p>This segment is used to provide free text information related to the application error. Example: Example: FTX+AA0+1+78E:23:2+X:X:X:X:XXX+AA ' Example: FTX+AA0+1+001::ZZZ '</p>					

Max. Occ. = Maximum Occurrence, St = Status, * = Restricted Codes
 Status: M=Mandatory, R=Required, O=Optional, C=Conditional, D=Dependent, A=Advised, N=Not used

Segment Layout

No. Seg	St	Max. Occ.				
SG4	C	99999	ERC-FTX-SG5			
A group of segments to identify the application error(s) within a specified received message and to give specific details related to the error type or to precise the type of acknowledgement.						
SG5	C	9	RFF-FTX			
A group of segments to specify the functional entity reference (e.g. goods item level, equipment level) relating to the specified error; further details can be added to identify the error more precisely.						
13	RFF	M	1	Reference		
To specify a reference.						
Business Term	DE	EDIFACT	Format	St	*	Description
	C506	Reference		M		
	1153	Reference code qualifier	an..3	M		AAN Delivery schedule number AGG Dispute number APQ Commercial account summary reference number IV Invoice number ON Order number (buyer)
	1154	Reference identifier	an..70	R		This number is the same number as in the BGM segment (DE 1004) of the message which is being acknowledged.
	1156	Document line identifier	an..6	O		This number is the same number as in the LIN segment (DE 1082) of the message which is being acknowledged.
<p>This segment is used to specify reference numbers related to the message which is being acknowledged.</p> <p>Example: The line being acknowledged is line 23 of the order with number 652744.</p> <p>Example: RFF+ON:X:X' Example: RFF+ON:652744:23'</p>						

Max. Occ. = Maximum Occurrence, St = Status, * = Restricted Codes

Status: M=Mandatory, R=Required, O=Optional, C=Conditional, D=Dependent, A=Advised, N=Not used

Segment Layout

No. Seg	St	Max. Occ.				
SG4	C	99999	ERC-FTX-SG5			
A group of segments to identify the application error(s) within a specified received message and to give specific details related to the error type or to precise the type of acknowledgement.						
SG5	C	9	RFF-FTX			
A group of segments to specify the functional entity reference (e.g. goods item level, equipment level) relating to the specified error; further details can be added to identify the error more precisely.						
14	FTX	C	9	Free text		
To provide free form or coded text information.						
Business Term	DE	EDIFACT	Format	St	*	Description
	4451	Text subject code qualifier	an..3	M		AAO Error description (free text)
	4453	Free text function code	an..3	N		
	C107	Text reference		N		
	4441	Free text value code	an..17			
	C108	Text literal		R		
	4440	Free text value	an..51	M		
	4440	Free text value	an..51	O		
	4440	Free text value	an..51	O		
	4440	Free text value	an..51	O		
	4440	Free text value	an..51	O		
This segment is used to provide free text information related to the application error. Example: Example: FTX+1E+++X:X:X:X:X' Example: FTX+AAO+++THE IDENTIFICATION NUMBER IS WRONG'						

Max. Occ. = Maximum Occurrence, St = Status, * = Restricted Codes
Status: M=Mandatory, R=Required, O=Optional, C=Conditional, D=Dependent, A=Advised, N=Not used

Segment Layout

No. Seg	St	Max. Occ.				
15	UNT	M 1	Message trailer To end and check the completeness of a message.			
Business Term	DE	EDIFACT	Format	St	*	Description
	0074	Number of segments in the message	n..6	M		The total number of segments in the message is specified here.
	0062	Message reference number	an..14	M		The message reference numbered detailed here should equal the one specified in the UNH segment.
<p>This segment is a mandatory UN/EDIFACT segment. It must always be the last segment in the message. Example: Example: UNT+13+ME000001' Example: UNT+11+ME000001'</p>						

Max. Occ. = Maximum Occurrence, St = Status, * = Restricted Codes
 Status: M=Mandatory, R=Required, O=Optional, C=Conditional, D=Dependent, A=Advised, N=Not used

Segment Layout

No. Seg	St	Max. Occ.				
16	UNZ	M 1	Interchange trailer To end and check the completeness of an interchange.			
Business Term	DE	EDIFACT	Format	St	*	Description
	0036	Interchange control count	n..6	M		Number of messages or functional groups within an interchange.
	0020	Interchange control reference	an..14	M		Identical to DE 0020 in UNB segment.
<p>This segment is used to provide the trailer of an interchange. DE 0036: If functional groups are used, this is the number of functional groups within the interchange. If functional groups are not used, this is the number of messages within the interchange.</p> <p>Example: UNZ+1+12345555 ' Example: UNZ+5+12345555 '</p>						

Max. Occ. = Maximum Occurrence, St = Status, * = Restricted Codes

Status: M=Mandatory, R=Required, O=Optional, C=Conditional, D=Dependent, A=Advised, N=Not used

Used Codes

0001	<p>Syntax identifier Coded identification of the agency controlling a syntax and syntax level used in an interchange.</p> <p>Notes: 1. a3, upper case, Controlling Agency (e.g. UNO=UN/ECE) and a1 stating level (e.g. A) (which together give UNOA).</p>
UNOA	<p>UN/ECE level A As defined in the basic code table of ISO 646 with the exceptions of lower case letters, alternative graphic character allocations and national or application-oriented graphic character allocations.</p>
UNOB	<p>UN/ECE level B As defined in the basic code table of ISO 646 with the exceptions of alternative graphic character allocations and national or application-oriented graphic character allocations.</p>
UNOC	<p>UN/ECE level C As defined in ISO/IEC 8859-1 : Information technology - Part 1: Latin alphabet No. 1.</p>
UNOD	<p>UN/ECE level D As defined in ISO/IEC 8859-2 : Information technology - Part 2: Latin alphabet No. 2.</p>
UNOE	<p>UN/ECE level E As defined in ISO/IEC 8859-5 : Information technology - Part 5: Latin/Cyrillic alphabet.</p>
UNOF	<p>UN/ECE level F As defined in ISO 8859-7 : Information processing - Part 7: Latin/Greek alphabet.</p>
0002	<p>Syntax version number Version number of the syntax identified in the syntax identifier (0001)</p> <p>Notes: 1. Increments 1 for each version.</p>
3	<p>Version 3 ISO 9735 Amendment 1:1992. GS1 Description: Syntax version number 3. This code can be used with all of the character sets (A, B, C, D, E and F).</p>

Used Codes

0007	<p>Partner identification code qualifier Qualifier referring to the source of codes for the identifiers of interchanging partners.</p> <p>Notes: 1. Used with sender/recipient identification code.</p>
14	<p>GS1 Partner identification code assigned by GS1, an international organization of GS1 Member Organizations that manages the GS1 System.</p>
0025	<p>Recipient's reference/password qualifier Qualifier for the recipient's reference or password.</p> <p>Notes: 1. If specified in IA.</p>
AA	<p>Reference Recipient's reference/password is a reference.</p>
BB	<p>Password Recipient's reference/password is a password.</p>
0029	<p>Processing priority code Code determined by the sender requesting processing priority for the interchange.</p> <p>Notes: 1. Used if specified in IA.</p>
A	<p>Highest priority Requested processing priority is the highest.</p>
0031	<p>Acknowledgement request Code determined by the sender for acknowledgement of the interchange.</p> <p>Notes: 1. Set = 1 if sender requests acknowledgement, i.e. UNB and UNZ segments received and identified.</p>
1	<p>Requested Acknowledgement is requested.</p>
0035	<p>Test indicator Indication that the interchange is a test.</p> <p>Notes: 1. Set = 1 if the interchange is a test. Otherwise not used.</p>

Used Codes

1	Interchange is a test Indicates that the interchange is a test.
5	Interchange is a service provider test Indicates that this interchange is a test with a service provider.
0051	Controlling agency Code to identify the agency controlling the specification, maintenance and publication of the message type.
UN	UN/CEFACT United Nations Centre for Trade Facilitation and Electronic Business (UN/CEFACT). GS1 Description: UN Economic Commission for Europe (UN/ECE), Committee on the development of trade (TRADE), Working Party on facilitation of international trade procedures (WP.4).
0052	Message version number Version number of a message type. Notes: 1. If UNG/UNE is used, shall be identical in UNG and UNE. The representation of 0052 was specified as n..3 in version 1 of ISO 9735.
D	Draft version/UN/EDIFACT Directory Message approved and issued as a draft message (Valid for directories published after March 1993 and prior to March 1997). Message approved as a standard message (Valid for directories published after March 1997).
0054	Message release number Release number within the current message type version number (0052). Notes: 1. The representation of 0054 was specified as n..3 in version 1 of ISO 9735.
01B	Release 2001 - B Message approved and issued in the second 2001 release of the UNTDID (United Nations Trade Data Interchange Directory).
0057	Association assigned code A code assigned by the association responsible for the design and maintenance of the message type concerned, which further identifies the message.
EAN004	GS1 version control number (GS1 Permanent Code) Indicates that the message is an EANCOM message in version 004.

Used Codes

0065	<p>Message type Code identifying a type of message and assigned by its controlling agency.</p> <p>Notes: 1. Type of message being transmitted.</p>
APERAK	<p>Application error and acknowledgement message A code to identify the application error and acknowledgement message. GS1 Description: The function of this message is: a) to inform a message issuer that his message has been received by the addressee's application and has been rejected due to errors encountered during its processing in the application. b) to acknowledge to a message issuer the receipt of his message by the addressee's application.</p>
1001	<p>Document name code Code specifying the document name.</p>
1	<p>Certificate of analysis Certificate providing the values of an analysis.</p>
2	<p>Certificate of conformity Certificate certifying the conformity to predefined definitions.</p>
3	<p>Certificate of quality Certificate certifying the quality of goods, services etc.</p>
4	<p>Test report Report providing the results of a test session.</p>
9	<p>Price/sales catalogue A document/message to enable the transmission of information regarding pricing and catalogue details for goods and services offered by a seller to a buyer.</p>
10	<p>Party information Document/message providing basic data concerning a party.</p>
35	<p>Inventory report A message specifying information relating to held inventories.</p>
44	<p>Transport status report A message to report the transport status and/or change in the transport status (i.e. event) between agreed parties.</p>
46	<p>Banking status A banking status document and/or message.</p>
51	<p>Price/sales catalogue response A document providing a response to a previously sent price/sales catalogue.</p>

Used Codes

54	<p>Legal statement of an account</p> <p>A statement of an account containing the booked items as in the ledger of the account servicing financial institution.</p>
55	<p>Listing statement of an account</p> <p>A statement from the account servicing financial institution containing items pending to be booked.</p>
56	<p>Closing statement of an account</p> <p>Last statement of a period containing the interest calculation and the final balance of the last entry date.</p>
67	<p>Commercial dispute</p> <p>Document/message issued by a party (usually the buyer) to indicate that one or more invoices or one or more credit notes are disputed for payment.</p>
77	<p>Consignment status report</p> <p>Message covers information about the consignment status.</p>
78	<p>Inventory movement advice</p> <p>Advice of inventory movements.</p>
82	<p>Metered services invoice</p> <p>Document/message claiming payment for the supply of metered services (e.g., gas, electricity, etc.) supplied to a fixed meter whose consumption is measured over a period of time.</p>
83	<p>Credit note related to financial adjustments</p> <p>Document message for providing credit information related to financial adjustments to the relevant party, e.g., bonuses.</p>
84	<p>Debit note related to financial adjustments</p> <p>Document/message for providing debit information related to financial adjustments to the relevant party.</p>
105	<p>Purchase order</p> <p>Document/message issued within an enterprise to initiate the purchase of articles, materials or services required for the production or manufacture of goods to be offered for sale or otherwise supplied to customers.</p>
130	<p>Invoicing data sheet</p> <p>Document/message issued within an enterprise containing data about goods sold, to be used as the basis for the preparation of an invoice.</p>
141	<p>Advising items to be booked to a financial account</p> <p>A document and/or message advising of items which have to be booked to a financial account.</p>
172	<p>Authorisation to plan and suggest orders</p> <p>Document or message that authorises receiver to plan orders, based on information in this message, and send these orders as suggestions to the sender.</p>

Used Codes

173	Authorisation to plan and ship orders Document or message that authorises receiver to plan and ship orders based on information in this message.
174	Drawing The document or message is a drawing. GS1 Description: A message used for the administration of the exchange of external objects.
182	Balance confirmation Confirmation of a balance at an entry date.
213	Request for financial cancellation The message is a request for financial cancellation.
214	Pre-authorized direct debit(s) The message contains pre-authorized direct debit(s).
220	Order Document/message by means of which a buyer initiates a transaction with a seller involving the supply of goods or services as specified, according to conditions set out in an offer, or otherwise known to the buyer.
221	Blanket order Usage of document/message for general order purposes with later split into quantities and delivery dates and maybe delivery locations.
223	Lease order Document/message for goods in leasing contracts.
224	Rush order Document/message for urgent ordering.
225	Repair order Document/message to order repair of goods.
226	Call off order Document/message to provide split quantities and delivery dates referring to a previous blanket order.
227	Consignment order Order to deliver goods into stock with agreement on payment when goods are sold out of this stock.
230	Purchase order change request Change to an purchase order already sent.
231	Purchase order response Response to an purchase order already received.
236	Delivery forecast A message which enables the transmission of delivery or product forecasting requirements.

Used Codes

237	<p>Cross docking services order A document or message to order cross docking services. GS1 Description: An order requesting cross docking services for goods to be delivered to a retailer.</p>
238	<p>Non-pre-authorized direct debit(s) The message contains non-pre-authorized direct debit(s).</p>
240	<p>Delivery instructions Document/message issued by a buyer giving instructions regarding the details of the delivery of goods ordered. GS1 Description: A message from a party to another party who has control over ordered goods, providing instructions to despatch a consignment according to conditions specified in the message.</p>
241	<p>Delivery schedule Usage of DELFOR-message. GS1 Description: A message which enables the transmission of delivery scheduling or product forecasting requirements.</p>
243	<p>Pre-authorized direct debit request(s) The message contains pre-authorized direct debit request(s).</p>
244	<p>Non-pre-authorized direct debit request(s) The message contains non-pre-authorized direct debit request(s).</p>
251	<p>Inquiry This is a request for information. GS1 Description: A message enabling the sender to inquire on a product or a group of products from a master product catalogue or file according to criteria defined in the message.</p>
252	<p>Response to previous banking status message A response to a previously sent banking status message.</p>
258	<p>Standing order An order to supply fixed quantities of products at fixed regular intervals.</p>
261	<p>Self billed credit note A document which indicates that the customer is claiming credit in a self billing environment.</p>
262	<p>Consolidated credit note - goods and services Credit note for goods and services that covers multiple transactions involving more than one invoice.</p>
263	<p>Inventory adjustment status report A message detailing statuses related to the adjustment of inventory.</p>

Used Codes

270	<p>Delivery note</p> <p>Paper document attached to a consignment informing the receiving party about contents of this consignment.</p>
289	<p>Product data message</p> <p>A message to submit master data, a set of data that is rarely changed, to identify and describe products a supplier offers to their (potential) customer or buyer.</p> <p>GS1 Description: A message between parties containing master data, to identify and describe products available for supply or for information purposes. This information of long validity does not include commercial terms and conditions but technical and functional product descriptions.</p>
291	<p>Delivery schedule response</p> <p>A message providing a response to a previously transmitted delivery schedule.</p>
297	<p>Instruction to collect</p> <p>A message instructing a party to collect goods.</p>
305	<p>Application error and acknowledgement</p> <p>A message to inform a message issuer that a previously sent message has been received by the addressee's application, or that a previously sent message has been rejected by the addressee's application.</p>
308	<p>Delcredere credit note</p> <p>A credit note sent to the party paying on behalf of a number of buyers.</p>
310	<p>Offer/quotation</p> <p>Document/message which , with a view to concluding a contract, sets out the conditions under which the goods are offered.</p>
311	<p>Request for quote</p> <p>Document/message requesting a quote on specified goods or services.</p>
315	<p>Contract</p> <p>Document/message evidencing an agreement between the seller and the buyer for the supply of goods or services; its effects are equivalent to those of an order followed by an acknowledgement of order.</p>
325	<p>Proforma invoice</p> <p>Document/message serving as a preliminary invoice, containing - on the whole - the same information as the final invoice, but not actually claiming payment.</p>
335	<p>Booking request</p> <p>Document/message issued by a supplier to a carrier requesting space to be reserved for a specified consignment, indicating desirable conveyance, despatch time, etc.</p>
338	<p>Items booked to a financial account report</p> <p>A message reporting items which have been booked to a financial account.</p>

Used Codes

340	Shipping instructions Document/message advising details of cargo and exporter's requirements for its physical movement.
341	Shipper's letter of instructions (air) Document/message issued by a consignor in which he gives details of a consignment of goods that enables an airline or its agent to prepare an air waybill.
342	Report of transactions for information only A message reporting transactions for information only.
345	Ready for despatch advice Document/message issued by a supplier informing a buyer that goods ordered are ready for despatch.
347	Order status enquiry A message enquiring the status of previously sent orders.
348	Order status report A message reporting the status of previously sent orders.
350	Despatch order Document/message issued by a supplier initiating the despatch of goods to a buyer (consignee).
351	Despatch advice Document/message by means of which the seller or consignor informs the consignee about the despatch of goods.
376	Standing inquiry on product information A product inquiry which stands until it is cancelled. GS1 Description: An initial download and any future changes made to the data within the standing request is automatically sent to the buyer as they occur, until the standing request is cancelled. Notes: A standing product inquiry implies that the supplier will send both a one-time download and notification of all future changes to the requested trade item until the standing request is deleted. A standing product inquiry can only be modified by deleting the original request and initiating a new request.
380	Commercial invoice Document/message claiming payment for goods or services supplied under conditions agreed between seller and buyer.
381	Credit note - goods and services Document/message for providing credit information to the relevant party.
382	Commission note Document/message in which a seller specifies the amount of commission, the percentage of the invoice amount, or some other basis for the calculation of the commission to which a sales agent is entitled.

Used Codes

383	Debit note - goods and services Document/message for providing debit information to the relevant party.
384	Corrected invoice Commercial invoice that includes revised information differing from an earlier submission of the same invoice.
385	Consolidated invoice Commercial invoice that covers multiple transactions involving more than one vendor. GS1 Description: Commercial invoice that covers multiple transactions involving more than one delivery.
386	Prepayment invoice An invoice to pay amounts for goods and services in advance; these amounts will be subtracted from the final invoice.
388	Tax invoice An invoice for tax purposes.
389	Self-billed invoice An invoice the invoicee is producing instead of the seller.
390	Delcredere invoice An invoice sent to the party paying for a number of buyers.
393	Factored invoice Invoice assigned to a third party for collection.
397	Commercial account summary response A document providing a response to a previously sent commercial account summary message.
400	Exceptional order An order which falls outside the framework of an agreement. GS1 Description: An order which falls outside the framework of an agreement or an order containing non-standard information.
401	Transshipment order An order requesting the supply of products packed according to the final delivery point which will be moved across a dock in a distribution centre without further handling.
402	Cross docking order An order requesting the supply of products which will be de-consolidated in the distribution centre and re-consolidated according to final delivery location.
447	Collection order Document/message whereby a bank is instructed (or requested) to handle financial and/or commercial documents in order to obtain acceptance and/or payment, or to deliver documents on such other terms and conditions as may be specified.

Used Codes

452	<p>Multiple payment order</p> <p>Document/message containing a payment order to debit one or more accounts and to credit one or more beneficiaries.</p>
481	<p>Remittance advice</p> <p>Document/message advising of the remittance of payment.</p>
493	<p>Statement of account message</p> <p>Usage of STATAC-message.</p>
527	<p>Self billed debit note</p> <p>A document which indicates that the customer is claiming debit in a self billing environment.</p>
610	<p>Forwarding instructions</p> <p>Document/message issued to a freight forwarder, giving instructions regarding the action to be taken by the forwarder for the forwarding of goods described therein.</p>
630	<p>Shipping note</p> <p>Document/message provided by the shipper or his agent to the carrier, multimodal transport operator, terminal or other receiving authority, giving information about export consignments offered for transport, and providing for the necessary receipts and declarations of liability. (Sometimes a multipurpose cargo handling document also fulfilling the functions of document 632, 633, 650 and 655).</p> <p>GS1 Description:</p> <p>Document/message provided by the shipper or his agent to the carrier, multimodal transport operator, terminal or other receiving authority, giving information about export consignments offered for transport, and providing for the necessary receipts and declarations of liability.</p>
632	<p>Goods receipt</p> <p>Document/message to acknowledge the receipt of goods and in addition may indicate receiving conditions.</p> <p>GS1 Description:</p> <p>Message addressing the business needs related to the goods receipt or advising discrepancies between despatched or ordered/planned goods.</p>
700	<p>Waybill</p> <p>Non-negotiable document evidencing the contract for the transport of cargo.</p>
701	<p>Universal (multipurpose) transport document</p> <p>Document/message evidencing a contract of carriage covering the movement of goods by any mode of transport, or combination of modes, for national as well as international transport, under any applicable international convention or national law and under the conditions of carriage of any carrier or transport operator undertaking or arranging the transport referred to in the document.</p>

Used Codes

705	<p>Bill of lading</p> <p>Negotiable document/message which evidences a contract of carriage by sea and the taking over or loading of goods by carrier, and by which carrier undertakes to deliver goods against surrender of the document. A provision in the document that goods are to be delivered to the order of a named person, or to order, or to bearer, constitutes such an undertaking.</p>
706	<p>Bill of lading original</p> <p>The original of the bill of lading issued by a transport company. When issued by the maritime industry it could signify ownership of the cargo.</p>
707	<p>Bill of lading copy</p> <p>A copy of the bill of lading issued by a transport company.</p>
719	<p>General message</p> <p>Document/message providing agreed textual information. GS1 Note: Replaces GS1 Temporary Code 14E.</p>
720	<p>Rail consignment note (generic term)</p> <p>Transport document constituting a contract for the carriage of goods between the sender and the carrier (the railway). For international rail traffic, this document must conform to the model prescribed by the international conventions concerning carriage of goods by rail, e.g. CIM Convention, SMGS Convention.</p>
721	<p>Product data response</p> <p>Document/message responding to a previously received Product Data document/message. GS1 Note: Replaces GS1 Temporary Code 1E.</p>
725	<p>Manufacturer raised order</p> <p>Document/message providing details of an order which has been raised by a manufacturer. GS1 Note: Replaces GS1 Temporary Code 22E.</p>
726	<p>Manufacturer raised consignment order</p> <p>Document/message providing details of a consignment order which has been raised by a manufacturer. GS1 Note: Replaces GS1 Temporary Code 23E.</p>
727	<p>Price/sales catalogue not containing commercial information</p> <p>A price/sales catalogue message containing no commercial such as prices, terms or conditions data. GS1 Note: Replaces GS1 Temporary Code 24E.</p>
728	<p>Price/sales catalogue containing commercial information</p> <p>A price/sales catalogue message including commercial such as prices, terms or conditions data. GS1 Note: Replaces GS1 Temporary Code 25E.</p>
729	<p>Returns advice</p> <p>Document/message by means of which the buyer informs the seller about the despatch of returned goods. GS1 Note: Replaces GS1 Temporary Code 35E.</p>

Used Codes

730	<p>Road consignment note</p> <p>Transport document/message which evidences a contract between a carrier and a sender for the carriage of goods by road (generic term). Remark: For international road traffic, this document must contain at least the particulars prescribed by the convention on the contract for the international carriage of goods by road (CMR).</p>
731	<p>Commercial account summary</p> <p>A message enabling the transmission of commercial data concerning payments made and outstanding items on an account over a period of time. GS1 Note: Replaces GS1 Temporary Code 49E.</p>
732	<p>Announcement for returns</p> <p>A message by which a party announces to another party details of goods for return due to specified reasons (e.g. returns for repair, returns because of damage, etc). GS1 Note: Replaces GS1 Temporary Code 70E.</p>
733	<p>Instruction for returns</p> <p>A message by which a party informs another party whether and how goods shall be returned. GS1 Note: Replaces GS1 Temporary Code 71E.</p>
734	<p>Sales forecast report</p> <p>A message enabling companies to exchange or report electronically, basic sales forecast data related to products or services, including the corresponding location, time period, product identification, pricing and quantity information. It enables the recip. GS1 Note: Replaces GS1 Temporary Code 72E.</p>
735	<p>Sales data report</p> <p>A message enabling companies to exchange or report electronically, basic sales data related to products or services, including the corresponding location, time period, product identification, pricing and quantity information. It enables the recipient to process the information automatically and use it for production, marketing or statistical purposes. GS1 Note: Replaces GS1 Temporary Code 73E.</p>
736	<p>Standing inquiry on complete product information</p> <p>A product inquiry which stands until it is cancelled. It requests not only the updates since last time, but always the complete product information of a data supplier. This means that within the standing request every time a complete download of the respective data is automatically sent to the data inquirer.</p>
737	<p>Proof of delivery</p> <p>A message by which a consignee provides for a carrier proof of delivery of a consignment.</p>
738	<p>Cargo/goods handling and movement message</p> <p>A message from a party to a warehouse, distribution centre, or logistics service provider identifying the handling services and where required the movement of specified goods, limited to warehouses within the jurisdiction of the distribution centre or logistics service provider. GS1 Note: Replaces GS1 Temporary Code 90E.</p>

Used Codes

739	<p>Metered services consumption report supporting an invoice Document/message providing metered consumption details supporting an invoice. GS1 Note: Replaces GS1 Temporary Code 94E.</p>
740	<p>Air waybill Document/message made out by or on behalf of the shipper which evidences the contract between the shipper and carrier(s) for carriage of goods over routes of the carrier(s) and which is identified by the airline prefix issuing the document plus a serial (IATA).</p>
742	<p>Metered services consumption report Document/message providing metered consumption details. GS1 Note: Replaces GS1 Temporary Code 99E.</p>
747	<p>Payroll deductions advice A message sent by a party (usually an employer or its representative) to a service providing organisation, to detail payroll deductions paid on behalf of its employees to the service providing organisation. GS1 Note: Replaces GS1 Temporary Code YA3.</p>
748	<p>Consignment despatch advice Document/message by means of which the supplier informs the buyer about the despatch of goods ordered on consignment (goods to be delivered into stock with agreement on payment when goods are sold out of this stock). GS1 Note: Replaces GS1 Temporary Code YA7.</p>
763	<p>Forwarder's certificate of transport Negotiable document/message issued by a forwarder to certify that he has taken charge of a specified consignment for despatch and delivery in accordance with the consignor's instructions, as indicated in the document, and that he accepts responsibility for delivery of the goods to the holder of the document through the intermediary of a delivery agent of his choice. E.g. FIATA-FCT.</p>
770	<p>Booking confirmation Document/message issued by a carrier to confirm that space has been reserved for a consignment in means of transport.</p>
781	<p>Arrival notice (goods) Notification from the carrier to the consignee in writing, by telephone or by any other means (express letter, message, telegram, etc.) informing him that a consignment addressed to him is being or will shortly be held at his disposal at a specified point in the place of destination.</p>
811	<p>Export licence Permit issued by a government authority permitting exportation of a specified commodity subject to specified conditions as quantity, country of destination, etc. Synonym: Embargo permit.</p>
821	<p>Despatch note model T1 Transit declaration for goods circulating under internal community transit procedures (between European Union (EU) countries).</p>

Used Codes

822	Despatch note model T2 Ascertainment that the declared goods were originally produced in an European Union (EU) country.
830	Goods declaration for exportation Document/message by which goods are declared for export Customs clearance, conforming to the layout key set out at Appendix I to Annex C.1 concerning outright exportation to the Kyoto convention (CCC). Within a Customs union, "for despatch" may have the same meaning as "for exportation".
852	Sanitary certificate Document/message issued by the competent authority in the exporting country evidencing that alimentary and animal products, including dead animals, are fit for human consumption, and giving details, when relevant, of controls undertaken.
861	Certificate of origin Document/message identifying goods, in which the authority or body authorized to issue it certifies expressly that the goods to which the certificate relates originate in a specific country. The word "country" may include a group of countries, a region or a part of a country. This certificate may also include a declaration by the manufacturer, producer, supplier, exporter or other competent person.
890	Dangerous goods declaration Document/message issued by a consignor in accordance with applicable conventions or regulations, describing hazardous goods or materials for transport purposes, and stating that the latter have been packed and labelled in accordance with the provisions of the relevant conventions or regulations.
898	Pre-packed cross docking consignment order A consignment order requesting the supply of products packed according to the final delivery point which will be moved across a dock in a distribution centre without further handling. GS1 Note: replaces YD1 (GS1 Temporary code)
910	Import licence, application for Document/message in which an interested party applies to the competent body for authorization to import either a limited quantity of articles subject to import restrictions, or an unlimited quantity of such articles during a limited period, and specifies the kind of articles, their origin and value, etc.
911	Import licence Document/message issued by the competent body in accordance with import regulations in force, by which authorization is granted to a named party to import either a limited quantity of designated articles or an unlimited quantity of such articles during a limited period, under conditions specified in the document.
938	Tax declaration (general) Document/message containing a general tax declaration.

Used Codes

951	<p>TIF forms</p> <p>International Customs transit document by which the sender declares goods for carriage by rail in accordance with the provisions of the 1952 International Convention to facilitate the crossing of frontiers for goods carried by rail (TIF Convention of UIC).</p>
952	<p>TIR Carnet</p> <p>International Customs document (International Transit by Road), issued by a guaranteeing association approved by the Customs authorities, under the cover of which goods are carried, in most cases under Customs seal, in road vehicles and/or containers in compliance with the requirements of the Customs TIR Convention of the International Transport of Goods under cover of TIR Carnets (UN/ECE).</p>
954	<p>EUR 1 certificate of origin</p> <p>Undefined Section</p> <p>Customs certificate used in preferential goods interchanges between EC countries and EC external countries.</p>
991	<p>Government contract</p> <p>Document/message describing a contract with a government authority.</p>
14E	<p>General message (GS1 Temporary Code)</p> <p>Document/message providing agreed textual information.</p> <p>GS1 Note: Code marked for deletion. Use value 719 instead.</p>
1E	<p>Product data response (GS1 Temporary Code)</p> <p>A message responding to a previously received Product Data message.</p> <p>GS1 Note: Code marked for deletion. Use value 721 instead.</p>
22B	<p>Order for retained approval copies (GS1 Temporary Code)</p> <p>Description to be provided.</p> <p>GS1 Note: Code marked for deletion.</p>
22E	<p>Manufacturer raised order (GS1 Temporary Code)</p> <p>Document/message providing details of an order which has been raised by a manufacturer.</p> <p>GS1 Note: Code marked for deletion. Use value 725 instead.</p>
23E	<p>Manufacturer raised consignment order (GS1 Temporary Code)</p> <p>Document/message providing details of a consignment order which has been raised by a manufacturer.</p> <p>GS1 Note: Code marked for deletion. Use value 726 instead.</p>
24E	<p>Price/sales catalogue not containing pricing information (GS1 Temporary Code)</p> <p>A price/sales catalogue message containing no commercial terms or conditions data.</p> <p>GS1 Note: Code marked for deletion. Use value 727 instead.</p>
25E	<p>Price/sales catalogue containing pricing information (GS1 Temporary Code)</p> <p>A price/sales catalogue message containing only commercial terms or conditions data.</p> <p>GS1 Note: Code marked for deletion. Use value 728 instead.</p>

Used Codes

26E	<p>Consignment issue (GS1 Permanent Code)</p> <p>Document/message providing details of a consignment issue which has been raised by a buyer.</p>
27E	<p>Release Order (GS1 Permanent Code)</p> <p>Document/message providing ability for buyer to send out a "Release Order" according to a blanket order previously sent through.</p>
2E	<p>Data distribution profile (GS1 Temporary Code)</p> <p>Message containing instructions on the distribution of data stored in a database.</p>
31B	<p>Quote used for bookseller's new title notices (GS1 Temporary Code)</p> <p>A quotation raised by a bookseller as a way of informing prospective buyers of new titles.</p>
35E	<p>Returns advice (GS1 Temporary Code)</p> <p>Document/message by means of which the buyer informs the seller about the despatch or impending despatch of returned goods.</p> <p>GS1 Note: Code marked for deletion. Use value 729 instead.</p>
49E	<p>Commercial account summary (GS1 Temporary Code)</p> <p>A message enabling the transmission of commercial data concerning payments made and outstanding items on an account over a period of time.</p> <p>GS1 Note: Code marked for deletion. Use value 731 instead.</p>
70E	<p>Announcement for returns (GS1 Temporary Code)</p> <p>A message by which a party announces to another party details of goods for return due to specified reasons (e.g. returns for repair, returns because of damage, etc).</p> <p>GS1 Note: Code marked for deletion. Use value 732 instead.</p>
71E	<p>Instruction for returns (GS1 Temporary Code)</p> <p>A message by which a party informs another party whether and how goods shall be returned.</p> <p>GS1 Note: Code marked for deletion. Use value 733 instead.</p>
72E	<p>Sales forecast report (GS1 Temporary Code)</p> <p>A message enabling companies to exchange or report electronically, basic sales forecast data related to products or services, including the corresponding location, time period, product identification, pricing and quantity information. It enables the recipient to process the information automatically and use it for production, planning, marketing or statistical purposes.</p> <p>GS1 Note: Code marked for deletion. Use value 734 instead.</p>
73E	<p>Sales data report (GS1 Temporary Code)</p> <p>A message enabling companies to exchange or report electronically, basic sales data related to products or services, including the corresponding location, time period, product identification, pricing and quantity information. It enables the recipient to process the information automatically and use it for production, marketing or statistical purposes.</p> <p>GS1 Note: Code marked for deletion. Use value 735 instead.</p>

Used Codes

76C	<p>Standing inquiry on complete product information (GS1 Temporary Code) A product inquiry which stands until it is cancelled. It requests not only the updates since last time, but always the complete product information of a data supplier. This means that within the standing request every time a complete download of the respective data is automatically sent to the datainquirer. GS1 Note: Code marked for deletion. Use value 736 instead.</p>
78E	<p>Proof of delivery (GS1 Temporary Code) A message by which a consignee provides for a carrier proof of delivery of a consignment. GS1 Note: Code marked for deletion. Use value 737 instead.</p>
90E	<p>Cargo/goods handling and movement message (GS1 Temporary Code) A message from a party to a warehouse, distribution centre, or logistics service provider identifying the handling services and where required the movement of specified goods, limited to warehouses within the jurisdiction of the distribution centre or logistics service provider. GS1 Note: Code marked for deletion. Use value 738 instead.</p>
94E	<p>Metered services consumption report invoice support (GS1 Temporary Code) A Metered Services Consumption Report is a communication between trading parties, or their agents, providing consumption and where required associated technical information at a location(s) for a product(s) or service(s) where the supply is recorded using a meter(s) to support information contained in commercial invoices. GS1 Note: Code marked for deletion. Use value 739 instead.</p>
99E	<p>Metered services consumption report (GS1 Temporary Code) A Metered Services Consumption Report is a communication between trading parties, or their agents, providing consumption and where required associated technical information at a location(s) for a product(s) or service(s) where the supply is recorded using a meter(s). GS1 Note: Code marked for deletion. Use value 742 instead.</p>
YA3	<p>Payroll deductions advice (GS1 Temporary Code) A message sent by a party (usually an employer or its representative) to a service providing organisation, to detail payroll deductions paid on behalf of its employees to the service providing organisation. GS1 Note: Code marked for deletion. Use value 747 instead.</p>
YA5	<p>Intermediate handling cross docking despatch advice (GS1 Temporary Code) Document by means of which the supplier or consignor informs the buyer, consignee or the distribution centre about the despatch of goods needing intermediate handling.</p>
YA6	<p>Pre-packed cross docking [transshipment] despatch advice (GS1 Temporary Code) Document by means of which the supplier or consignor informs the buyer, consignee or distribution centre about the despatch of pre-packed goods.</p>

Used Codes

YA7	<p>Consignment despatch advice (GS1 Temporary Code)</p> <p>Document/message by means of which the supplier informs the buyer about the despatch of goods ordered on consignment (goods to be delivered into stock with agreement on payment when goods are sold out of this stock). GS1 Note: Code marked for deletion. Use value 748 instead.</p>
YB3	<p>Ready for transshipment despatch advice (GS1 Temporary Code)</p> <p>Document/message by means of which the supplier or consignor informs the buyer, consignee or the distribution center that the goods ordered are ready for transshipment.</p>
YB4	<p>Media campaign document (GS1 Temporary Code)</p> <p>Document providing the details of a media campaign</p>
YB5	<p>Product Marketing document, detailed (GS1 Temporary Code)</p> <p>Marketing document providing a detailed functional description of a product or goods/services.</p>
YB6	<p>Product Marketing document, concise (GS1 Temporary Code)</p> <p>Marketing document providing a concise functional description of a product or goods/services.</p>
YB7	<p>Self billed debit note correction (GS1 Temporary Code)</p> <p>Debit note message that includes revised information differing from an earlier submission of the same debit note in a self billing environment.</p>
YB8	<p>Debit note correction (GS1 Temporary Code)</p> <p>Debit note message that includes revised information differing from an earlier submission of the same debit note.</p>
YC1	<p>Consumer pickup order (GS1 Permanent Code)</p> <p>Consumer order with pickup at store.</p>
YC2	<p>Consumer home delivery order (GS1 Permanent Code)</p> <p>Consumer order with home delivery.</p>
YC3	<p>Consumer pickup delivery note (GS1 Permanent Code)</p> <p>Despatch advice for a consumer order with pickup at store.</p>
YC4	<p>Consumer home delivery note (GS1 Permanent Code)</p> <p>Despatch advice for a consumer order with home delivery.</p>
YD1	<p>Pre-packed cross docking consignment order (GS1 Temporary Code)</p> <p>A consignment order requesting the supply of products packed according to the final delivery point which will be moved across a dock in a distribution centre without further handling. GS1 Note: Code marked for deletion. Use value 898 instead.</p>

Used Codes

1131	Code list identification code Code identifying a user or association maintained code list. Notes: 1. The codes for this data element are provided by the code list responsible agency defined in data element 3055.
23	Clearing house automated payment Self explanatory. Notes: This code value will be removed effective with directory D.04A. GS1 Description: Banking community' automated payment clearing system.
25	Bank identification Code for identification of banks. Notes: This code value will be removed effective with directory D.04A.
106	Incoterms 1980 (4110) Code to indicate applicable Incoterm (1980 edition) under which seller undertakes to deliver merchandise to buyer (ICC). Incoterms 1990: use 4053 only. Notes: This code value will be removed effective with directory D.04A.
132	Charge Identification of a type of charge. Notes: This code value will be removed effective with directory D.04A.
154	Bank branch sorting identification Identification of a specific branch of a bank. Notes: This code value will be removed effective with directory D.04A.
157	Clearing code Identification of the responsible bank/clearing house which has cleared or is ordered to do the clearing. Notes: This code value will be removed effective with directory D.04A.
166	Social security identification Code assigned by the authority competent to issue social security identification to identify a person. Notes: This code value will be removed effective with directory D.04A.

Used Codes

174	<p>Citizen identification Self explanatory.</p> <p>Notes: This code value will be removed effective with directory D.04A.</p> <p>GS1 Description: Code issued by national authority competent to issue citizen identification to identify a person.</p>
1E	<p>Incoterms 1990 (GS1 Temporary Code) Incoterms 1990 as published by the International Chamber of Commerce (ICC).</p>
2E	<p>Incoterms 2000 (GS1 Temporary Code) Incoterms 2000 as published by the International Chamber of Commerce (ICC).</p>
3E	<p>Incoterms 2010 (GS1 Temporary Code) Incoterms 2010 as published by the International Chamber of Commerce (ICC).</p>
ADR	<p>Accord European au transport international dangereuses (GS1 Temporary Code) A European agreement concerning the international carriage of dangerous goods by road.</p>
BR	<p>Brand (GS1 Temporary Code) An identifying mark or label on the products of a particular company, or the kind or make of a commodity.</p>
CA	<p>Category (GS1 Temporary Code) A class or division in a scheme of classification.</p>
CO	<p>Colour (GS1 Temporary Code) Description of the colour required/available on the goods.</p>
FL	<p>Flavor (GS1 Temporary Code) The characteristic quality of goods.</p>
HMT	<p>Hazardous material standard text (GS1 Temporary Code) Code indicating agreed standard text on hazardous materials.</p>
LOC	<p>Location Code (GS1 Temporary Code) This is a code to indicate where the EAS tag is located on the Trade Item. Values include On outside of Trade Item, Concealed inside Trade Item, Integrated Inside Trade Item.</p>
OAG	<p>Organic Claim Agency (GS1 Temporary Code) A governing body that creates and maintain standards related to organic products.</p>
OCO	<p>Organic Trade Item Code (GS1 Temporary Code) Used to indicate the organic status of a trade item or of one or more of its components.</p>

Used Codes

OUM	Ordering unit of measure (GS1 Temporary Code) The alternate Unit of Measure of how Trade Items are ordered by the Retailer under one Unit of Measure, but sold under another Unit of Measure.
SKB	SKRS recommendation (GS1 Temporary Code) SKRS recommendation for standard clothes hanger.
SRN	Service relation number (GS1 Temporary Code) A number used to identify a database entry which records recurring services, e.g., treatment of a patient in a hospital, usage by a member of a library facilities, etc.
ST	Style (GS1 Temporary Code) Specific or characteristic design in any goods.
SUM	Selling unit of measure (GS1 Temporary Code) Describes the measurement used for selling unit of the Trade Item to the end consumer.
SZ	Size (GS1 Temporary Code) Any of a series of graded classifications of measure into which goods are divided.
SZG	Size Group (GS1 Temporary Code) A description of the variable size that is necessary to uniquely specify the size of the item in conjunction with the nonpackaged size dimension.
TYP	Type Code (GS1 Temporary Code) This is a code to indicate the type of EAS tag located on the Trade Item. Values include Acousto-Magnetic, Electro-Magnetic, Ink or dye, Microwave, Radio Frequency.
X11	Diet Allergen (GS1 Temporary Code) Indication of which dietary or allergen marks that are on the package.
X12	Environment (GS1 Temporary Code) Indication of which environmental marks (e.g. recycling schemes) that are on trade item package.
X13	Ethical (GS1 Temporary Code) Indication of which ethical trading marks that are on the package.
X14	Free Form (GS1 Temporary Code) Indication of which free-from marks that are on the package.
X15	Expiration date (GS1 Temporary Code) Indicates the type of expiration date marked on the packaging.
X16	Nesting Direction (GS1 Temporary Code) Depicts the arrangement of two items that nest together specifically whether they nest against each other or on top of each other.
X17	Package Marks Hygienic (GS1 Temporary Code) Indication of which hygiene markings are present in the product package

Used Codes

X18	<p>Hazardous Components are Removable (GS1 Temporary Code)</p> <p>An indicator if any hazardous components contained within the trade item can easily be separated from the other materials to facilitate product recycling.</p>
X19	<p>Trade Item Has Refuse Obligations (GS1 Temporary Code)</p> <p>Indicates if there are special disposal obligations that apply to the trade item for example INTRASTAT.</p>
X20	<p>Trade Item Is Designed for Easy Disassembly (GS1 Temporary Code)</p> <p>Indicates that the trade item is designed for easy disassembly by recycling facilities using standard industry tools.</p>
X21	<p>Trade Item Is Rigid Plastic Packaging Container (GS1 Temporary Code)</p> <p>Indicates that a product is or is contained in a Rigid Plastic Packaging Container (RPPC) as defined by laws in the target market.</p>
X22	<p>Trade Item Is ROHS Compliant (GS1 Temporary Code)</p> <p>Indicates if the product is compliant with the European Union RoHS Directive.</p>
X23	<p>Trade Item Is Universal Waste (GS1 Temporary Code)</p> <p>Indicates if a product can be considered universal waste.</p>
X24	<p>Trade Item Is Consumer Upgradeable Or Maintainable (GS1 Temporary Code)</p> <p>Indicates if a product can be easily upgraded or have parts replaced by the consumer.</p>
X25	<p>Trade Item Contains Short Chain Chlorinated Paraffins (GS1 Temporary Code)</p> <p>Indicate if the trade item and/or its components contain paints, coatings, plastics or other materials containing short chain chlorinated paraffins (SCCPs).</p>
X26	<p>Trade Item Contains Pesticide (GS1 Temporary Code)</p> <p>Indicates if the trade item is advertised or labelled as a chemical or contains a chemical that is advertised or labelled to kill, repel or prevent the growth of any living organism.</p>
X27	<p>Trade Item Contains Propellant (GS1 Temporary Code)</p> <p>Indicates if a trade item contains a compressed gas or propellant.</p>
X28	<p>Trade Item Contains Polyvinyl Chloride (GS1 Temporary Code)</p> <p>Indicate if product contains Polyvinyl Chloride (PVC), a widely used thermoplastic polymer.</p>
X29	<p>Trade Item Chemical Is Not Intended For Human Consumption (GS1 Temporary Code)</p> <p>Indicates that the trade item is or contains a Liquid, Gel, Paste, Powder, or Flammable solid not intended for human consumption (ingested).</p>
X30	<p>ROHS Compliance Failure Material (GS1 Temporary Code)</p> <p>The material used in the trade item that does not comply with the ROHS Directives</p>

Used Codes

X31	<p>Packaging Terms And Condition (GS1 Temporary Code)</p> <p>Indicates if the packaging given in the described packaging configuration is a rented, exchangeable, against deposit or one way/not reusable.</p>
X32	<p>Warranty Effective Date Type (GS1 Temporary Code)</p> <p>The type of date associated with the warranty trade item usually expressed as an event date for the item for example date of purchase, date of manufacture or date of delivery.</p>
X33	<p>Warranty Type (GS1 Temporary Code)</p> <p>Type of warranty available for the part, e.g. labour, distance, extended service.</p>
X35	<p>Warranty Constraint (GS1 Temporary Code)</p> <p>Defines the relationship between different guarantee terms, e.g. "and", "or", "the stronger", "the weaker".</p>
X36	<p>Seasonal Availability End Date (GS1 Temporary Code)</p> <p>Indicates the end date of the trade item's seasonal availability.</p>
X37	<p>Seasonal Availability Start Date (GS1 Temporary Code)</p> <p>Indicates the start date of the trade item's seasonal availability.</p>
X38	<p>Season Calendar Year (GS1 Temporary Code)</p> <p>This element indicates the calendar year in which the trade item is seasonally available.</p>
X39	<p>Season Parameter (GS1 Temporary Code)</p> <p>Indication of the season, in which the trade item is available.</p>
X40	<p>Trade Item Automatic Power Down is Enabled (GS1 Temporary Code)</p> <p>An indicator whether a product is enabled with auto power down feature when shipped to the customer.</p>
X41	<p>Electrical Usage Agency Code (GS1 Temporary Code)</p> <p>The agency that regulates electrical usage for products within a target market.</p>
X42	<p>Nesting Type (GS1 Temporary Code)</p> <p>Depicts whether a nested item fits inside or over the other item in a nesting relationship.</p>
X43	<p>Display Dimension Type Code (GS1 Temporary Code)</p> <p>Depicts certain display scenarios used for measurement.</p>
X44	<p>Manufacturer Has Take Back Program (GS1 Temporary Code)</p> <p>Indicates if the manufacturer of the trade item offers any take back programs to consumers for the product to be reused, remanufactured or recycled by the manufacturer.</p>
X45	<p>Display Resolution (GS1 Temporary Code)</p> <p>The display resolution of a television or computer display.</p>
X46	<p>Orientation Preference Sequence (GS1 Temporary Code)</p> <p>Depicts the preferred sequence of orientation used to communicate the manufacturers relative preferences of orientation.</p>

Used Codes

X47	Orientation Type (GS1 Temporary Code) Depicts via code a display orientation for a trade item.
X48	Electrical Usage Trade Item Classification Code (GS1 Temporary Code) A classification code value from a product classification scheme provided to drive required information for electrical usage.
X49	Electrical Usage Trade Item Classification Name (GS1 Temporary Code) A classification name from a product classification scheme provided to drive required information for electrical usage.
X50	Electrical Usage SubClassification Code (GS1 Temporary Code) A sub-classification code value from a product classification scheme provided to drive required information for electrical usage.
X51	Electrical Usage SubClassification Name (GS1 Temporary Code) A sub-classification name provided to drive required information for electrical usage.
X52	Confirmation Status Code (GS1 Temporary Code) The CIC Confirmation Code must be of a type of code number that can be generated automatically by a computer system.
X53	Confirmation Status Code Description (GS1 Temporary Code) Provides the code description that matches up with the Code that can possibly be generated automatically by a computer system.
X54	Additional Confirmation Status Description (GS1 Temporary Code) Provides a way to communicate human entered information that may not be covered by the machine to machine codes and descriptions.
X55	Corrective Action (GS1 Temporary Code) Provides the corrective action code to fix the issue that caused the problem.
X56	Expected Corrective Information (GS1 Temporary Code) Provides the expected corrective information via a human entered information that may not be covered by the machine to machine codes.
X57	Electrical Usage Trade Item Classification Agency (GS1 Temporary Code) A classification agency or organisation whose product classification scheme is being provided to drive required information for electrical usage.
X58	ASFIS (GS1 Permanent Code) FAO alph-3 code list for fish species identification, commercial name & scientific name.
X59	FAO fishing areas (GS1 Permanent Code) FAO fishing areas codelist.
X60	FAO Fishing gear type (GS1 Permanent Code) FAO Fishing gear type codelist.
X61	EU fish quality (GS1 Permanent Code) EU fish quality grade code list (E, A, B, C).

Used Codes

X62	EU fish size (GS1 Permanent Code) EU fish standardized size code list (1, 2, 3, 4, 5 & One_Size).
X63	EU fish presentation (GS1 Permanent Code) EU fish presentation code list (3 or 5 char alpha code).
ZZZ	Mutually defined Self explanatory. Note : This code value will be removed effective with directory D.04A.
1153	Reference code qualifier Code qualifying a reference.
AAB	Proforma invoice number [1088] Reference number assigned by the seller to a Proforma Invoice.
AAC	Documentary credit number [1172] Reference number assigned by issuing bank to a Documentary credit.
AAF	Debit card number A reference number identifying a debit card.
AAG	Offer or quotation number Reference number assigned by issuing party to an offer.
AAJ	Delivery order number Reference number assigned by issuer to a delivery order.
AAK	Despatch advice number Reference number assigned by issuing party to a despatch advice.
AAL	Drawing number Reference number identifying a specific product drawing.
AAM	Waybill number Reference number assigned to a waybill, see: 1001 = 700.
AAN	Delivery schedule number Reference number assigned by buyer to a delivery schedule.
AAO	Consignee's shipment reference number [1362] Reference assigned by the consignee to a shipment.
AAQ	Unit load device (e.g. container) identification number [8260] Marks (letters and/or numbers) which identify a unit load device e.g. freight container.
AAS	Transport document number [1188] Reference assigned by the carrier or his agent to the transport document.
AAT	Master label number Identifies the master label number of any package type.

Used Codes

AAU	Despatch note number [1128] Reference number assigned by the seller to a Despatch Note.
ABD	Customs tariff number (7357) Code number of the goods in accordance with the tariff nomenclature system of classification in use where the Customs declaration is made.
ABE	Declarant's reference number Unique reference number assigned to a document or a message by the declarant for identification purposes.
ABO	Originator's reference A unique reference assigned by the originator.
ABP	Declarant's Customs identity number Reference to the party whose posted bond or security is being declared in order to accept responsibility for a goods declaration and the applicable duties and taxes.
ABQ	Importer reference number Reference number assigned by the importer to identify a particular shipment for his own purposes.
ABT	Customs declaration number [1426] Number, assigned or accepted by Customs, to identify a Goods declaration.
ACD	Additional reference number Reference number provided in addition to another given reference.
ACE	Related document number Reference number identifying a related document.
ACK	Bank reference Cross reference issued by financial institution.
ACL	Principal reference number A number that identifies the principal reference.
ACW	Reference number to previous message Reference number assigned to the message which was previously issued (e.g. in the case of a cancellation, the primary reference of the message to be cancelled will be quoted in this element).
ACX	Banker's acceptance Reference number for banker's acceptance issued by the accepting financial institution.
ADB	Matured certificate of deposit Reference number for certificate of deposit allocated by issuing financial institution.
ADC	Loan Reference number for loan allocated by lending financial institution.

Used Codes

ADD	Analysis number/test number Number given to a specific analysis or test operation.
ADE	Account number Identification number of an account.
AE	Authorization for expense (AFE) number A number that identifies an authorization for expense (AFE). GS1 Description: A number providing authorization for a party to incur an expense.
AEK	Payment order number A number that identifies a payment order.
AER	Project specification number Reference number identifying a project specification.
AES	Primary reference A number that identifies the primary reference.
AFO	Beneficiary's reference Reference of the beneficiary.
AFS	Beneficiary's bank reference Reference number of the beneficiary's bank.
AGA	Agreement to pay number A number that identifies an agreement to pay. GS1 Description: A reference number guaranteeing a payment.
AGB	Contract party reference number Reference number assigned to a party for a particular contract.
AGG	Dispute number Reference number to a dispute notice. GS1 Description: A reference number identifying a previously transmitted commercial dispute.
AGT	Service group identification number Identification used for a group of services.
AGW	Scheme/plan number Reference number assigned to a service scheme or plan.
AHJ	Payee's reference number Reference number of the party to be paid.
AHL	Creditor's reference number Reference number of the party to whom a debt is owed.
AHM	Debtor's reference number Reference number of the party who owes an amount of money.

Used Codes

AHU	Request for quote number Reference number assigned by the requestor to a request for quote.
AID	Certificate of conformity Certificate certifying the conformity to predefined definitions.
AIJ	Customer's individual transaction reference number Customer's reference number allocated by the customer to one specific transaction.
AIK	Bank's individual transaction reference number Bank's reference number allocated by the bank to one specific transaction.
AIZ	Consolidated invoice number Invoice number into which other invoices are consolidated.
AJS	Agreement number A number specifying an agreement between parties.
AJT	Standard Industry Classification (SIC) number A number specifying a standard industry classification.
AKJ	Direct debit reference Reference number assigned to the direct debit operation.
AKM	Replenishment purchase order range start number Starting number of a range of purchase order numbers assigned by the buyer to vendor's replenishment orders.
AKO	Action authorization number A reference number authorizing an action.
ALK	Consignee's invoice number The invoice number assigned by a consignee.
ALL	Message batch number A number identifying a batch of messages.
ALM	Previous delivery schedule number A reference number identifying a previous delivery schedule.
ALN	Physical inventory recount reference number A reference to a re-count of physically held inventory.
ALO	Receiving advice number A reference number to a receiving advice.
ALP	Returnable container reference number A reference number identifying a returnable container.
ALQ	Returns notice number A reference number to a returns notice.

Used Codes

ALR	Sales forecast number A reference number identifying a sales forecast.
ALS	Sales report number A reference number identifying a sales report.
ALT	Previous tax control number A reference number identifying a previous tax control number. GS1 Description: A reference number identifying a previous Tax Control (TAXCON) message number.
ALV	Registered capital reference Registered capital reference of a company.
AML	Replenishment purchase order range end number Ending number of a range of purchase order numbers assigned by the buyer to vendor's replenishment orders.
AMT	Goods and Services Tax identification number An identification number assigned to an organization collecting Goods and Services Taxes (GST).
ANJ	Authorization number A number which uniquely identifies an authorization.
ANL	Deposit reference number A reference number identifying a deposit. GS1 Description: A reference number identifying a physical deposit made to a financial account by a party through the bank branch network.
ANX	Clearing reference Reference allocated by a clearing procedure.
ANZ	Direct debit reference Reference of the direct debit. Notes: This code value will be removed effective with directory D.02A.
AOA	Documentary payment reference Reference of the documentary payment.
AP	Accounts receivable number Reference number assigned by accounts receivable department to the account of a specific debtor.
APF	Price/sales catalogue response reference number A reference number identifying a response to a price/sales catalogue.
APG	General purpose message reference number A reference number identifying a general purpose message. EDIFACT

Used Codes

APH	Invoicing data sheet reference number A reference number identifying an invoicing data sheet.
API	Inventory report reference number A reference number identifying an inventory report.
APQ	Commercial account summary reference number A reference number identifying a commercial account summary.
AQQ	Activite Principale Exercee (APE) identifier The French industry code for the main activity of a company.
AQS	Nomenclature Activity Classification Economy (NACE) identifier A European industry classification code used to identify the activity of a company.
ARZ	Stock adjustment number A number identifying a stock adjustment.
ASE	Duty free products security number A security number allocated for duty free products.
ASF	Duty free products receipt authorisation number Authorisation number allocated for the receipt of duty free products.
ASG	Party information message reference Reference identifying a party information message.
ASI	Proof of delivery reference number A reference number identifying a proof of delivery which is generated by the goods recipient.
ASJ	Supplier's credit claim reference number A reference number identifying a supplier's credit claim.
ASK	Picture of actual product Reference identifying the picture of an actual product.
ASL	Picture of a generic product Reference identifying a picture of a generic product.
ASO	Password Code used for authentication purposes.
ASV	Product data file number The number of a product data file.
ATB	Purchase for export Customs agreement number A number assigned by a Customs authority allowing the purchase of goods free of tax because they are to be exported immediately after the purchase. EDIFACT
AUB	Party reference The reference to a party

Used Codes

AUD	Collection reference A reference identifying a collection.
AUG	Importer's letter of credit reference Letter of credit reference issued by importer.
AUJ	Proposed purchase order reference number A reference number assigned to a proposed purchase order.
AUK	Application for financial support reference number Reference number assigned to an application for financial support.
AUL	Manufacturing quality agreement number Reference number of a manufacturing quality agreement.
AUQ	Customs binding ruling number Binding ruling number issued by customs.
AUR	Customs non-binding ruling number Non-binding ruling number issued by customs.
AUY	International Standard Industrial Classification (ISIC) code A code specifying an international standard industrial classification.
AUZ	Customs pre-approval ruling number Pre-approval ruling number issued by Customs.
AVB	Product characteristics directory A reference to a product characteristics directory. EDIFACT
AVD	Inventory report request number A reference to a product characteristics directory. EDIFACT
AVG	Slaughterhouse approval number Veterinary licence number allocated by a national authority to a Slaughterhouse. EDIFACT
AVH	Meat cutting plant approval number Veterinary licence number allocated by a national authority to a meat cutting plant. EDIFACT
AVQ	Place of packing approval number Approval Number of the place where goods are packaged. Approval number of the place where goods are packaged. In the meat sector, some additional information is required for traceability purposes: cutting party, slaughterhouse, ..
AVS	Mandate Reference Reference to a specific mandate given by the relevant party for underlying business or action.

Used Codes

AWB	Air waybill number Reference number assigned to an air waybill, see: 1001 = 740.
AWS	Hygienic Certificate number, national Nationally set Hygienic Certificate number, such as sanitary, epidemiologic.
AWT	Administrative Reference Code Reference number assigned by Customs to a 'shipment of excise goods'.
AWV	Phone number A sequence of digits used to call from one telephone line to another in a public telephone network.
AWW	Buyer's fund number A reference number indicating the fund number used by the buyer. GS1 Note: Replaces GS1 Temporary Code BFN.
AWX	Company trading account number A reference number identifying a company trading account. GS1 Note: Replaces GS1 Temporary Code CAN.
AWY	Reserve goods identifier A reference number identifying goods in stock which have been reserved for a party. GS1 Note: Replaces GS1 Temporary Code GRN.
AWZ	Handling and movement reference number A reference number identifying a previously transmitted cargo/goods handling and movement message. GS1 Note: Replaces GS1 Temporary Code HN.
AXA	Instruction to despatch reference number A reference number identifying a previously transmitted instruction to despatch message. GS1 Note: Replaces GS1 Temporary Code IDR.
AXB	Instruction for returns number A reference number identifying a previously communicated instruction for return message. GS1 Note: Replaces GS1 Temporary Code IRN.
AXC	Metered services consumption report number A reference number identifying a previously communicated metered services consumption report. GS1 Note: Replaces GS1 Temporary Code MSC.
AXD	Order status enquiry number A reference number to a previously sent order status enquiry. GS1 Note: Replaces GS1 Temporary Code OSC.
AXE	Firm booking reference number A reference number identifying a previous firm booking. GS1 Note: Replaces GS1 Temporary Code PFB.

Used Codes

AXF	<p>Product inquiry number</p> <p>A reference number identifying a previously communicated product inquiry. GS1 Note: Replaces GS1 Temporary Code PIE.</p>
AXG	<p>Split delivery number</p> <p>A reference number identifying a split delivery. GS1 Note: Replaces GS1 Temporary Code SDR.</p>
AXH	<p>Service relation number</p> <p>A reference number identifying the relationship between a service provider and a service client, e.g., treatment of a patient in a hospital, usage by a member of a library facility, etc. GS1 Note: Replaces GS1 Temporary Code SNR.</p>
AXI	<p>Serial shipping container code</p> <p>Reference number identifying a logistic unit. GS1 Note: Replaces GS1 Temporary Code SSC.</p>
AXJ	<p>Test specification number</p> <p>A reference number identifying a test specification. GS1 Note: Replaces GS1 Temporary Code TS.</p>
AXK	<p>Transport status report number</p> <p>[1125] A reference number identifying a transport status report. GS1 Note: Replaces GS1 Temporary Code TSE.</p>
AXL	<p>Tooling contract number</p> <p>A reference number of the tooling contract. GS1 Note: Replaces GS1 Temporary Code XB5.</p>
AXM	<p>Formula reference number</p> <p>A reference number of a formula. GS1 Note: Replaces GS1 Temporary Code XB6.</p>
AXN	<p>Pre-agreement number</p> <p>A reference number identifying a pre-agreement. GS1 Note: Replaces GS1 Temporary Code XB7.</p>
AXO	<p>Product certification number</p> <p>Number assigned by a governing body (or their agents) to a product which certifies compliance with a standard. GS1 Note: Replaces GS1 Temporary Code XC1.</p>
AXP	<p>Consignment contract number</p> <p>Reference number identifying a consignment contract. GS1 Note: Replaces GS1 Temporary Code XC3.</p>
AXQ	<p>Product specification reference number</p> <p>Number assigned by the issuer to his product specification. GS1 Note: Replaces GS1 Temporary Code YA1.</p>
AXR	<p>Payroll deduction advice reference</p> <p>A reference number identifying a payroll deduction advice. GS1 Note: Replaces GS1 Temporary Code YA9.</p>

Used Codes

BC	Buyer's contract number Reference number assigned by buyer to a contract.
BFN	Buyer's fund number (GS1 Temporary Code) A reference number indicating the fund number used by the buyer. GS1 Note: Code marked for deletion. Use value AWW instead.
BM	Bill of lading number Reference number assigned to a bill of lading, see: 1001 = 705.
BN	Booking reference number [1016] Reference number assigned by the carrier or his agent when cargo space is reserved prior to loading.
BO	Blanket order number Reference number assigned by the order issuer to a blanket order.
BT	Batch number/lot number Reference number assigned by manufacturer to a series of similar products or goods produced under similar conditions.
CAN	Company trading account number (GS1 Temporary Code) A reference number identifying a company trading account. GS1 Note: Code marked for deletion. Use value AWX instead.
CBB	Order shipment grouping reference A reference number identifying the grouping of purchase orders into one shipment. GS1 Note: Replaces GS1 Temporary Code YB4.
CD	Credit note number Reference number assigned to a credit note.
CED	Debit Letter number Reference number identifying the letter of debit document. GS1 Note: Replaces GS1 Temporary Code YB8.
CFF	Animal farm licence number Veterinary licence number allocated by a national authority to an animal farm. GS1 Note: Replaces GS1 Temporary Code YC3.
CH	Customer catalogue number Number identifying a catalogue for customer's usage.
CK	Cheque number Unique number assigned to one specific cheque.
CMR	Road consignment note number Reference number assigned to a road consignment note, see: 1001 = 730.
CN	Carrier's reference number Reference number assigned by carrier to a consignment.

Used Codes

CNE	Consolidated reference number (GS1 Temporary Code) A number identifying a consolidated reference.
CO	Buyers order number [1022] Reference number assigned by the buyer to an order.
COF	Call off order number A number that identifies a call off order.
CR	Customer reference number Reference number assigned by the customer to a transaction.
CT	Contract number Reference number of a contract concluded between parties.
CU	Consignor's reference number [1140] Reference number assigned by a consignor to a particular shipment for his own purposes or for those of the consignee.
CZ	Cooperation contract number Number issued by a party concerned given to a contract on cooperation of two or more parties.
DDC	Direct debit contract reference (SWIFT Code) A reference number identifying a direct debit contract.
DL	Debit note number Reference number assigned by issuer to a debit note.
DM	Document number [1004] Reference number assigned to the document by the issuer.
DQ	Delivery note number Reference number assigned by the issuer to a delivery note.
ECN	External consolidation reference number (GS1 Temporary Code) A reference number assigned to identify an external consolidation.
EID	Economic operator identifier (EO-ID) (GS1 Temporary Code) Specify the economic operator identifier (EO-ID) number, e.g. in tobacco traceability.
ERC	External recap reference number (GS1 Temporary Code) A reference number identifying an external recap.
EX	Export licence number [1208] Reference number assigned by issuing authority to an Export Licence.
FC	Fiscal number Tax payer's number. Number assigned to individual persons as well as to corporates by a public institution; this number is different from the VAT registration number.

Used Codes

FF	Freight forwarder's reference number [1460] Reference number assigned to the consignment by the freight forwarder.
FI	File line identifier Number assigned by the file issuer or sender to identify a specific line.
FID	Facility identifier (F-ID) (GS1 Temporary Code) Identifies the place, for example the POS or warehouse where tobacco products are traded.
FV	File version number Number given to a version of an identified file.
FX	Foreign exchange contract number Reference number identifying a foreign exchange contract.
GC	Government contract number Number assigned to a specific government/public contract.
GN	Government reference number A number that identifies a government reference. GS1 Description: This code value should not be used to provide the tax identification number for a party (use code VA).
GRN	Goods reserve number (GS1 Temporary Code) A reference number identifying goods in stock which have been reserved for a party. GS1 Note: Code marked for deletion. Use value AWY instead.
HN	Handling and movement reference number (GS1 Temporary Code) A reference number identifying a previously transmitted cargo/goods handling and movement message. GS1 Note: Code marked for deletion. Use value AWZ instead.
HS	Harmonised system number Number specifying the goods classification under the Harmonised Commodity Description and Coding System of the Customs Co-operation Council (CCC).
HWB	House waybill number Reference number assigned to a house waybill, see: 1001 = 703.
IA	Internal vendor number Number identifying the company-internal vending department/unit.
IDR	Instruction to despatch reference number (GS1 Temporary Code) A reference number identifying a previously transmitted instruction to despatch message. GS1 Note: Code marked for deletion. Use value AXA instead.
IP	Import licence number [1106] Reference number assigned by the issuing authority to an Import Licence.

Used Codes

IRN	<p>Instruction for returns number (GS1 Temporary Code)</p> <p>A reference number identifying a previously communicated instruction for return message.</p> <p>GS1 Note: Code marked for deletion. Use value AXB instead.</p>
IT	<p>Internal customer number</p> <p>Number assigned by a seller, supplier etc. to identify a customer within his enterprise.</p>
IV	<p>Invoice number</p> <p>[1334] Reference number assigned by the seller to a Commercial Invoice.</p>
LC	<p>Letter of credit number</p> <p>Reference number identifying the letter of credit document.</p>
LI	<p>Line item reference number</p> <p>(1156) Reference number identifying a particular line in a document.</p>
MB	<p>Master bill of lading number</p> <p>Reference number assigned to a master bill of lading, see: 1001 = 704.</p>
MF	<p>Manufacturer's part number</p> <p>Reference number assigned by the manufacturer to his product or part.</p>
MG	<p>Meter unit number</p> <p>Number identifying a unique meter unit.</p>
MH	<p>Manufacturing order number</p> <p>Reference number assigned by manufacturer for a given production quantity of products.</p>
MR	<p>Message recipient</p> <p>A number that identifies the message recipient.</p> <p>GS1 Description: Party who receives the message.</p>
MS	<p>Message sender</p> <p>A number that identifies the message sender.</p> <p>GS1 Description: Party who sends the message.</p>
MSC	<p>Metered services consumption report (GS1 Temporary Code)</p> <p>A reference number identifying a previously communicated metered services consumption report.</p> <p>GS1 Note: Code marked for deletion. Use value AXC instead.</p>
MSS	<p>Manufacturer's material safety data sheet number</p> <p>A number that identifies a manufacturer's material safety data sheet.</p>
MWB	<p>Master air waybill number</p> <p>Reference number assigned to a master air waybill, see: 1001 = 741.</p>
ON	<p>Order number (buyer)</p> <p>[1022] Reference number assigned by the buyer to an order.</p>

Used Codes

OSE	Order status enquiry (GS1 Temporary Code) A reference number to a previously sent order status enquiry. GS1 Note: Code marked for deletion. Use value AXD instead.
PB	Payer's financial institution account number Originated company account number (ACH transfer), check, draft or wire.
PD	Promotion deal number Number assigned by a vendor to a special promotion activity.
PFB	Firm booking reference number (GS1 Temporary Code) A reference number identifying a previous firm booking. GS1 Note: Code marked for deletion. Use value AXE instead.
PIE	Product inquiry number (GS1 Temporary Code) A reference number identifying a previously communicated product inquiry number. GS1 Note: Code marked for deletion. Use value AXF instead.
PK	Packing list number (1014) Reference number assigned to a packing list, see: 1001 = 271.
PL	Price list number Reference number assigned to a price list. GS1 Description: This code should be used to identify a Price/Sales Catalogue (PRICAT) message.
POR	Purchase order response number Reference number assigned by the seller to an order response.
PP	Purchase order change number Reference number assigned by a buyer for a revision of a purchase order.
PQ	Payment reference Reference number assigned to a payment.
PR	Price quote number Reference number assigned by the seller to a quote.
PW	Prior purchase order number Reference number of a purchase order previously sent to the supplier.
PY	Payee's financial institution account number Receiving company account number (ACH transfer), check, draft or wire.
RA	Remittance advice number A number that identifies a remittance advice.
RAK	Rack identification (GS1 Temporary Code) Identification of a warehouse rack in the location for shipment pick-up.
RCE	Recap number (GS1 Temporary Code) A reference number identifying a recap.

Used Codes

RCN	Railway consignment note number Reference number assigned to a rail consignment note, see: 1001 = 720.
RF	Export reference number Reference number given to an export shipment.
SB	Sales region number A number that identifies a sales region.
SD	Sales department number A number that identifies a sales department.
SDR	Split delivery reference number (GS1 Temporary Code) A reference number identifying a split delivery. GS1 Note: Code marked for deletion. Use value AXG instead.
SE	Serial number Identification number of an item which distinguishes this specific item out of an number of identical items.
SN	Seal number [9308] Identification number on Customs or other seals affixed to containers or other transport units.
SNR	Service relation number (GS1 Temporary Code) A number used to identify a database entry which records recurring services, e.g., treatment of a patient in a hospital, usage by a member of a library facility, etc. GS1 Note: Code marked for deletion. Use value AXH instead.
SRN	Shipment reference number Reference number assigned to a shipment. GS1 Description: Reference number assigned by a consignor to a particular shipment for his own purposes or for those of the consignee.
SS	Seller's reference number Reference number assigned to a transaction by the seller.
SSC	Serial shipping container code (GS1 Temporary Code) Reference number identifying a serial shipping container or package. GS1 Note: Code marked for deletion. Use value AXI instead.
SZ	Specification number Number assigned by the issuer to his specification.
TAU	Aggregated level unique identifier (aUI) (GS1 Temporary Code) Reference the aggregated level unique identifier (aUI), e.g. in tobacco traceability.
TIN	Transport instruction number A reference number identifying a transport instruction. EDIFACT

Used Codes

TL	Tax exemption licence number Number assigned by the tax authorities to a party indicating its tax exemption authorization. This number could relate to a specified business type, a specified local area or a class of products.
TP	Test report number Reference number identifying a test report document relevant to the product.
TRB	Tribunal place registration number (GS1 Temporary Code) Registration number of a company at the tribunal place.
TS	Test specification number (GS1 Temporary Code) A reference number identifying a test specification. GS1 Note: Code marked for deletion. Use value AXJ instead.
TSE	Transport status number (GS1 Temporary Code) A reference number identifying a transport status message. GS1 Note: Code marked for deletion. Use value AXK instead.
TUU	Aggregated level unique identifier (upUI) (GS1 Temporary Code) Identifies the single pack of cigarettes issued by a central EU repository.
UC	Ultimate customer's reference number The originator's reference number as forwarded in a sequence of parties involved.
UCN	Unique consignment reference number (1202) Unique reference of a consignment (UCRN) used for identification purposes in documents and messages exchanged between parties in international trade. See also: Unique Identifier Code (UNIC) in UN/ECE Recommendation No. 8, March 1992.
UO	Ultimate customer's order number The originator's order number as forwarded in a sequence of parties involved.
VA	VAT registration number Unique number assigned by the relevant tax authority to identify a party for use in relation to Value Added Tax (VAT).
VN	Order number (supplier) Reference number assigned by supplier to a buyer's purchase order.
XA	Company/place registration number Company registration and place as legally required.
XA4	Account servicing bank reference (SWIFT Code) A reference number allocated by an account servicing bank.
XA5	Customer to customer reference number (SWIFT Code) A reference number exchanged between customers.
XA6	Third party reference number (SWIFT Code) A number used to identify references related to third parties.

Used Codes

XA8	Credit card number (SWIFT Code) A reference number identifying a credit card.
XB1	Clearing number (SWIFT Code) A reference number identifying a clearing.
XB5	Tooling contract number (GS1 Temporary Code) Number of the tooling contract. GS1 Note: Code marked for deletion. Use value AXL instead.
XB6	Formula number (GS1 Temporary Code) Number of the formula. GS1 Note: Code marked for deletion. Use value AXM instead.
XB7	Pre-agreement number (GS1 Temporary Code) Number identifying a pre-agreement. GS1 Note: Code marked for deletion. Use value AXN instead.
XC1	Product certification number (GS1 Temporary Code) Number assigned by a governing body (or their agents) to a product which certifies compliance with a standard. GS1 Note: Code marked for deletion. Use value AXO instead.
XC3	Consignment contract number (GS1 Temporary Code) Reference number identifying a consignment contract. GS1 Note: Code marked for deletion. Use value AXP instead.
YA1	Product specification reference number (GS1 Temporary Code) Number assigned by the issuer to his product specification. GS1 Note: Code marked for deletion. Use value AXQ instead.
YA3	Numbering per year (GS1 Temporary Code) Financial statement should be identified consecutively numbered per year.
YA6	Bank statement number (SWIFT Code) A reference number identifying a bank statement.
YA9	Payroll deduction advice reference (GS1 Temporary Code) A reference number identifying a payroll deduction advice. GS1 Note: Code marked for deletion. Use value AXR instead.
YB4	Order shipment grouping reference (GS1 Temporary Code) A reference number identifying the grouping of purchase orders into one shipment. GS1 Note: Code marked for deletion. Use value CBB instead.
YB8	Debit Letter (GS1 Temporary Code) Reference number identifying the letter of debit document. GS1 Note: Code marked for deletion. Use value CED instead.
YC1	Additional party identification (GS1 Temporary Code) Reference number to an additional party identification. This number may be the internal trading partner identification number used by a party to identify its trading parties.

Used Codes

YC3	Farm approval number (GS1 Temporary Code) Veterinary licence number allocated by a national authority to an animal farm.
YC6	Electrical and Electronic Equipment Producer registration number (GS1 Temporary Code) National registration number of the producers of Electrical and Electronic Equipment
YC7	Batteries and Accumulators Producer registration number (GS1 Temporary Code) National registration number of the producers of Batteries and Accumulators
ZZZ	Mutually defined reference number Number based on party agreement.
1225	Message function code Code indicating the function of the message.
6	Confirmation Message confirming the details of a previous transmission where such confirmation is required or recommended under the terms of a trading partner agreement.
9	Original Initial transmission related to a given transaction.
23	Transaction on hold Message not to be processed until further release information.
27	Not accepted Message to inform that the referenced message is not accepted by the recipient.
1373	Document status code Code specifying the status of a document.
1	Accepted The specified document is accepted.
2	Accompanying goods Notice that a specific document will be accompanying the goods.
3	Conditionally accepted The specified document is conditionally accepted.
4	To arrive by separate EDI message Notice that a specific document/message will be transmitted via a separate EDI message.
5	Information only Notice that the specific document or message is for information only.

Used Codes

6	To arrive by manual means Notice that a specific document or message will not be sent via EDI.
7	To be raised and sent Request for a specific message to be formatted and transmitted or a request for a specific document to be raised and sent.
8	Rejected The specified document is rejected.
9	To be printed The document or message is to be printed.
10	Document currently valid Specific document is currently valid.
17	Document with the goods Document not attached to the Customs declaration but is attached to the goods.
39	On hold The document or message will not be processed until further release information. GS1 Note: Replaces GS1 Temporary Code X1.
X1	On hold (GS1 Temporary Code) The document or message will not be processed until further release information. GS1 Note: Code marked for deletion. Use value 39 instead.
2005	Date or time or period function code qualifier Code qualifying the function of a date, time or period.
137	Document/message date/time (2006) Date/time when a document/message is issued. This may include authentication.
171	Reference date/time Date/time on which the reference was issued.
2379	Date or time or period format code Code specifying the representation of a date, time or period.
2	DDMMYY Calendar date: D = Day; M = Month; Y = Year.
101	YYMMDD Calendar date: Y = Year; M = Month; D = Day.
102	CCYYMMDD Calendar date: C = Century ; Y = Year ; M = Month ; D = Day.

Used Codes

104	MMWW-MMWW A period of time specified by giving the start week of a month followed by the end week of a month. Data is to be transmitted as consecutive characters without hyphen.
107	DDD Day's number within a specific year: D = Day.
108	WW Week's number within a specific year: W = Week.
109	MM Month's number within a specific year: M = Month.
110	DD Day's number within is a specific month.
201	YYMMDDHHMM Calendar date including time without seconds: Y = Year; M = Month; D = Day; H = Hour; M = Minute.
203	CCYYMMDDHHMM Calendar date including time with minutes: C=Century; Y=Year; M=Month; D=Day; H=Hour; M=Minutes.
204	CCYYMMDDHHMMSS Calendar date including time with seconds: C=Century;Y=Year; M=Month; D=Day;H=Hour;M=Minute;S=Second.
401	HHMM Time without seconds: H = Hour; m = Minute.
501	HHMMHHMM Time span without seconds: H = Hour; m = Minute;.
502	HHMMSS-HHMMSS Format of period to be given without hyphen.
602	CCYY Calendar year including century: C = Century; Y = Year.
609	YYMM Month within a calendar year: Y = Year; M = Month.
610	CCYYMM Month within a calendar year: CC = Century; Y = Year; M = Month.
615	YYWW Week within a calendar year: Y = Year; W = Week 1st week of January = week 01.
616	CCYYWW Week within a calendar year: CC = Century; Y = Year; W = Week (1st week of January = week 01).

Used Codes

713	YYMMDDHHMM-YYMMDDHHMM Format of period to be given in actual message without hyphen.
715	YYWW-YYWW A period of time specified by giving the start week of a year followed by the end week of year (both not including century). Data is to be transmitted as consecutive characters without hyphen.
717	YYMMDD-YYMMDD Format of period to be given in actual message without hyphen.
718	CCYYMMDD-CCYYMMDD Format of period to be given without hyphen.
719	CCYYMMDDHHMM-CCYYMMDDHHMM A period of time which includes the century, year, month, day, hour and minute. Format of period to be given in actual message without hyphen.
720	DHHMM-DHHMM Format of period to be given without hyphen (D=day of the week, 1=Monday; 2=Tuesday; ... 7=Sunday).
801	Year To indicate a quantity of years.
802	Month To indicate a quantity of months.
803	Week To indicate a quantity of weeks.
804	Day To indicate a quantity of days.
805	Hour To indicate a quantity of hours.
806	Minute To indicate a quantity of minutes.
810	Trimester To indicate a quantity of trimesters (three months).
811	Half month To indicate a quantity of half months.
21E	DDHHMM-DDHHMM (GS1 Temporary Code) Format of period to be given in actual message without hyphen.
3035	Party function code qualifier Code giving specific meaning to a party.

Used Codes

AB	Buyer's agent/representative Third party who arranged the purchase of merchandise on behalf of the actual buyer.
ACD	Party has access to all non publicly available data (GS1 Temporary Code) The identified party has access to all non publicly available pricing and non-pricing data associated with the current product.
ACN	Party has access only to non publicly available non-pricing data (GS1 Temporary Code) The identified party has access only to the non publicly available non-pricing data associated with the current product.
ACP	Party has access only to non publicly available pricing data (GS1 Temporary Code) The identified party has access only to the non publicly available pricing data associated with the current product.
AE	Declarant's agent/representative Any natural or legal person who makes a declaration to an official body on behalf of another natural or legal person, where legally permitted (CCC).
AG	Agent/representative (3196) Party authorized to act on behalf of another party.
AP	Accepting party (3352) Party accepting goods, products, services etc.
AS	Account servicing financial institution Identifies the financial institution servicing the account(s).
BE	Beneficiary The ultimate recipient of the funds. Normally the account owner who is reimbursed by the payor.
BF	Beneficiary's bank Identifies the account servicer for the beneficiary or the payee.
BK	Financial institution Party acting as financial institution.
BL	Bill of lading recipient Party to receive B/L.
BO	Broker or sales office Party acting in the name of the seller as broker or as sales office.
BQ	Cheque drawn bank Identifies the bank on which the cheque should be drawn, as instructed by the ordering customer.
BS	Bill and ship to Party receiving goods and relevant invoice.

Used Codes

BY	Buyer Party to whom merchandise and/or service is sold.
CA	Carrier (3126) Party undertaking or arranging transport of goods between named points.
CG	Carrier's agent Party authorized to act for or on behalf of carrier.
CH	Connecting carrier Owner or operator of a transportation conveyance to which goods in a given transaction will be transferred.
CK	Empty equipment despatch party Party from whose premises empty equipment will be or has been despatched.
CM	Customs Identification of customs authority relevant to the transaction or shipment.
CN	Consignee (3132) Party to which goods are consigned.
CO	Corporate office Identification of the Head Office within a company.
COD	Quotation requesting party The party sending the requests for quotation. GS1 Note: Replaces GS1 Temporary Code QP. EDIFACT
CPE	Central payment service (GS1 Temporary Code) Master of the conveyance. GS1 Description: A party providing central (or consolidated payment) services.
CPU	Central procurement party (GS1 Temporary Code) Party responsible for all aspects (e.g. tenders, orders, invoices, ..) of procurement.
CQ	Cheque order Party to which the cheque will be ordered, when different from the beneficiary.
CR	Empty equipment return party Party to whose premises empty equipment will be or has been returned.
CRB	Creditor's bank (SWIFT Code) Identifies the account servicer for the creditor.
CRE	Creditor (SWIFT Code) The party to be credited with funds.
CS	Consolidator Party consolidating various consignments, payments etc.

Used Codes

CW	Equipment owner Owner of equipment (container, etc.).
CX	Consignee's agent Party authorized to act on behalf of the consignee.
CZ	Consignor (3336) Party which, by contract with a carrier, consigns or sends goods with the carrier, or has them conveyed by him. Synonym: shipper, sender.
DBB	Debtor's bank (SWIFT Code) Identifies the account servicer for the debtor.
DCS	Temporary employee A person employed on a temporary basis.
DCT	Designer A party who designs.
DCU	Quotation delivered to Party to whom the quotation is to be or has been delivered. EDIFACT
DCV	Developer A party who develops.
DCX	Party to receive refund Party to whom a refund is given.
DEF	Meat cutter Person whose job is to cut up and/or mince meat. EDIFACT
DEQ	Shipper Party responsible for the shipment of goods.
DER	Source data pool A data pool that supports the functionality required by a data source such as data loading, publication, notification, registration, etc.
DES	Brand owner The owner of a brand.
DFZ	Article information responsible party The party responsible for article information. GS1 Note: Replaces GS1 Temporary Code IPD.
DGA	Price information responsible party The party responsible for price information. GS1 Note: Replaces GS1 Temporary Code IPR.

Used Codes

DGB	<p>Invoice processing party</p> <p>Party to whom the invoice is sent and who processes the invoice on behalf of the invoicee. Note, the invoicee is legally responsible for the invoice and can be different to the processing party.</p> <p>GS1 Note: Replaces GS1 Temporary Code ITO.</p>
DGC	<p>Logistic service provider</p> <p>A party providing logistic services for another party (e.g re-packing suppliers products) on products.</p> <p>GS1 Note: Replaces GS1 Temporary Code LSP.</p>
DGD	<p>Fattener</p> <p>Party which provides fattening services.</p> <p>GS1 Note: Replaces GS1 Temporary Code X51.</p>
DGE	<p>Breeder</p> <p>Party which provides breeding.</p> <p>GS1 Note: Replaces GS1 Temporary Code X52.</p>
DL	<p>Factor</p> <p>Company offering a financial service whereby a firm sells or transfers title to its accounts receivable to the factoring company.</p>
DM	<p>Party to whom documents are to be presented</p> <p>Party to whom documents are to be presented.</p>
DP	<p>Delivery party</p> <p>(3144) Party to which goods should be delivered, if not identical with consignee.</p> <p>GS1 Description: Party to which goods should be delivered, if not the same as the buyer.</p>
DS	<p>Distributor</p> <p>Party distributing goods, financial payments or documents.</p>
EM	<p>Party to receive electronic memo of invoice</p> <p>Party being informed about invoice issue (via EDI).</p>
EO	<p>Owner of equipment</p> <p>Party who owns equipment.</p>
EX	<p>Exporter</p> <p>(3030) Party who makes - or on whose behalf a Customs clearing agent or other authorized person makes - an export declaration. This may include a manufacturer, seller or other person. Within a Customs union, consignor may have the same meaning as exporter.</p>
FD	<p>Buyer's parent company</p> <p>Parent company, e.g. holding company.</p>
FP	<p>Freight/charges payer</p> <p>Party responsible for the payment of freight.</p>

Used Codes

FR	Message from Party where the message comes from.
FW	Freight forwarder Party arranging forwarding of goods.
GL	Socially insured person A person who is registered in a social security scheme.
GM	Inventory controller To specifically identify the party in charge of inventory control.
GO	Goods owner The party which owns the goods.
GQ	Slaughterer Party or person who has undertaken or will undertake a slaughter.
GW	Party fulfilling all operations Code indicating the fact that the party identified carries out all operations within that company's activities.
GX	Central catalogue party Party controlling a central catalogue.
GY	Inventory reporting party Party reporting inventory information.
GZ	Substitute supplier Party which may be in a position to supply products or services should the main usual supplier be unable to do so.
HP	Final message recipient To identify the final recipient of the message.
HQ	Owner of account (SWIFT Code) Identifies the owner of the account.
HX	Debtor (SWIFT Code) Party from whom payment is due.
I1	Intermediary bank 1 A financial institution between the ordered bank and the beneficiary's bank.
I2	Intermediary bank 2 A financial institution between the ordered bank and the beneficiary's bank.
II	Issuer of invoice (3028) Party issuing an invoice.
IM	Importer (3020) Party who makes - or on whose behalf a Customs clearing agent or other authorized person makes - an import declaration. This may include a person who has possession of the goods or to whom the goods are consigned.

Used Codes

IN	<p>Insurer</p> <p>A person or company offering insurance policies for premiums.</p>
IPA	<p>Party information party (GS1 Temporary Code)</p> <p>The party in a company who is responsible for the party information. The PARTIN message may be requested from or sent by this party.</p>
IPD	<p>Article information party (GS1 Temporary Code)</p> <p>The party in a company who is responsible for the pricing or other article information. The PRICAT or PRODAT messages may be requested from or sent by this party.</p> <p>GS1 Note: Code marked for deletion. Use value DFZ instead.</p>
IPR	<p>Price information party (GS1 Temporary Code)</p> <p>The party in a company who is responsible for the price information. The PRICAT message may be requested from or sent by this party.</p> <p>GS1 Note: Code marked for deletion. Use value DGA instead.</p>
ITO	<p>Invoice recipient party (GS1 Temporary Code)</p> <p>Party to whom the invoice is sent and who processes the invoice on behalf of the invoicee. Note, the invoicee is legally responsible for the invoice and can be different to the processing party.</p> <p>GS1 Note: Code marked for deletion. Use value DGB instead.</p>
IV	<p>Invoicee</p> <p>(3006) Party to whom an invoice is issued.</p>
JB	<p>Goods collection party</p> <p>Party that will collect or has collected the goods.</p> <p>GS1 Description:</p> <p>Party that will collect or has collected the goods.</p>
LC	<p>Party declaring the Value Added Tax (VAT)</p> <p>A code to identify the party who is responsible for declaring the Value Added Tax (VAT) on the sale of goods or services.</p>
LD	<p>Party recovering the Value Added Tax (VAT)</p> <p>A code to identify the party who is eligible to recover the Value Added Tax (VAT) on the sale of goods or services.</p>
LF	<p>Buyer's corporate office</p> <p>The identification of the buyer's corporate office.</p>
LG	<p>Supplier's corporate office</p> <p>The identification of the supplier's corporate office.</p>
LP	<p>Loading party</p> <p>Party responsible for the loading when other than carrier.</p>
LSP	<p>Logistic Service Provider (GS1 Temporary Code)</p> <p>A party providing logistic services for another party (e.g re-packing suppliers products) on products which may lead to added value for the product.</p> <p>GS1 Note: Code marked for deletion. Use value DGC instead.</p>

Used Codes

MA	Party for whom item is ultimately intended Party for whom item is ultimately intended.
MF	Manufacturer of goods Party who manufactures the goods.
MP	Manufacturing plant Self explanatory. GS1 Description: Industrial department of a company in which goods are manufactured with appropriate equipment and fittings.
MR	Message recipient A party to receive a message or messages.
MS	Document/message issuer/sender Issuer of a document and/or sender of a message.
N1	Notify party no. 1 The first party which is to be notified.
N2	Notify party no. 2 The second party which is to be notified.
NFP	No function priority allocated (GS1 Temporary Code) Code indicating that the party identified is capable of carrying out all or most functions within the party.
NI	Notify party (3180) Party to be notified of arrival of goods.
OB	Ordered by Party who issued an order. GS1 Description: Party who issued an order for goods and services.
OR	Ordered bank Identifies the account servicer for the ordering customer or payor.
OS	Original shipper The original supplier of the goods.
OV	Owner of means of transport (3126) Party owning the means of transport. No synonym of carrier = CA.
OY	Ordering customer Identifies the originator of the instruction. GS1 Description: Only used in financial messages.
P1	Contact party 1 First party to contact.

Used Codes

P2	Contact party 2 Second party to contact.
PB	Paying financial institution Financial institution designated to make payment.
PE	Payee Identifies the credit party when other than the beneficiary.
PF	Party to receive freight bill Party to whom the freight bill should be sent.
PL	Payor Identifies the debit party when other than the ordering customer (for banking purposes).
PO	Ordering party To be used only if ordering party and buyer are not identical.
PR	Payer (3308) Party initiating payment.
PW	Despatch party (3282) Party where goods are collected or taken over by the carrier (i.e. if other than consignor).
PX	Party to receive all documents A party which is named to be the recipient of all documents.
PY	Checking party Party or contact designated on behalf of carrier or his agent to establish the actual figures for quantities, weight, volume and/or (cube) measurements of goods or containers which are to appear in the transport contract and on which charges will be based.
RA	Central bank or regulatory authority Identifies central bank or regulatory authority which must be informed of certain aspects of a message.
RB	Receiving financial institution Financial institution designated to receive payment.
RE	Party to receive commercial invoice remittance Party to whom payment for a commercial invoice or bill should be remitted.
RH	Seller's financial institution Financial institution designated by seller to receive payment. RDFI (ACH transfers).
RV	Receiver of cheque Identifies the party which is to receive the actual cheque, when different from the receiver of funds.

Used Codes

SA	Sales person number (GS1 Temporary Code) The identification of a sales person number. GS1 Note: Code marked for deletion. Use value SE instead.
SE	Seller (3346) Party selling merchandise to a buyer. GS1 Note: Replaces GS1 Temporary Code SA.
SF	Ship from Identification of the party from where goods will be or have been shipped.
SN	Store number A party keeping a shop or store. GS1 Description: Number allocated to identify a store.
SR	Supplier's agent/representative (3254) Party representing the seller for the purpose of the trade transaction. GS1 Description: Party representing the supplier for the purpose of the trade transaction.
SS	Social securities collector's office Party collecting social securities premiums.
ST	Ship to Identification of the party to where goods will be or have been shipped.
SU	Supplier Party who supplies goods and/or services. GS1 Description: Party which provides service(s) and/or manufactures or otherwise has possession of goods, and consigns or makes them available in trade.
TC	Tax collector's office Party collecting taxes.
TPE	Testing party (GS1 Temporary Code) A party authorized to carry out a specified test.
TS	Party to receive certified test results Party to whom the certified test results should be sent.
UC	Ultimate consignee Party who has been designated on the invoice or packing list as the final recipient of the stated merchandise.
UD	Ultimate customer The final recipient of goods.
WH	Warehouse keeper (3022) Party taking responsibility for goods entered into a warehouse.
WS	Wholesaler Seller of articles, often in large quantities, to be retailed by others.

Used Codes

X47	Cash register number (GS1 Temporary Code) Number allocated to identify a cash register.
X48	Corporate identity (GS1 Temporary Code) The identity of party to whom all other parties of the same commercial organisation are linked.
X50	Mincing plant (GS1 Temporary Code) A place where the meat of animals is cut into very small pieces using a meat grinder. GS1 Note: Code marked for deletion.
X51	Fattener (GS1 Temporary Code) Party which fattens the animal. GS1 Note: Code marked for deletion. Use value DGD instead.
X52	Breeder (GS1 Temporary Code) Party which breeds the animal. GS1 Note: Code marked for deletion. Use value DGE instead.
X53	Content Owner (GS1 Temporary Code) Not available. GS1 Note: Code marked for deletion.
X54	Temperature variation (GS1 Temporary Code) Temperature variation upward or downward
X56	No / missing loading space (GS1 Temporary Code) The goods/consignment/equipment could not be loaded because of no/missing loading space.
ZZZ	Mutually defined Party specification mutually agreed between interchanging parties.
3045	Party name format code Code specifying the representation of a party name.
1	Name components in sequence as defined in description below Name component 1: Family name. Name component 2: Given name or initials. Name component 3: Given name or initials. Name component 4: Maiden name. Name component 5: Title Group of name components transmitted in sequence with name component 1 transmitted first. The maiden name is the family name given at birth of a female. Other names are self-explanatory.
3055	Code list responsible agency code Code specifying the agency responsible for a code list.
2	CEC (Commission of the European Communities) Generic: see also 140, 141, 142, 162. GS1 Description: Commission of the European Communities

Used Codes

3	IATA (International Air Transport Association) The airline industry's international organisation. GS1 Description: International Air Transport Association
5	ISO (International Organization for Standardization) International Organization of Standardization.
6	UN/ECE (United Nations - Economic Commission for Europe) United Nations Economic Commission for Europe.
7	CEFIC (Conseil Europeen des Federations de l'Industrie Chimique) EDI project for chemical industry.
8	EDIFICE Standardised electronic commerce forum for companies with interests in computing, electronics and telecommunications. GS1 Description: EDI Forum for companies with Interest in Computing and Electronics (EDI project for EDP/ADP sector).
9	GS1 GS1 (formerly EAN International), an organisation of GS1 Member Organisations, which manages the GS1 System. GS1 Description: GS1 International.
10	ODETTE Organization for Data Exchange through Tele-Transmission in Europe (European automotive industry project).
17	S.W.I.F.T. Society for Worldwide Interbank Financial Telecommunications s.c.
28	EDITEUR (European book sector electronic data interchange group) Code identifying the pan European user group for the book industry as an organisation responsible for code values in the book industry.
60	Assigned by national trade agency The code list is from a national agency.
65	GS1 France Organisation responsible for GS1 System in France.
68	GS1 Italy Organisation responsible for GS1 System in Italy.
83	US, National Retail Federation The National Retail Federation is the trade association for the general merchandise retailing industry. In addition to providing support and education services, they also maintain and publish standard colour and size codes for the retail industry.

Used Codes

84	DE, BRD (Gesetzgeber der Bundesrepublik Deutschland) German legislature.
86	Assigned by party originating the message Codes assigned by the party originating the message.
87	Assigned by carrier Codes assigned by the carrier.
88	Assigned by owner of operation Assigned by owner of operation (e.g. used in construction).
89	Assigned by distributor Codes assigned by a distributor.
90	Assigned by manufacturer Code assigned by the manufacturer.
91	Assigned by supplier or supplier's agent Codes assigned by a seller or seller's agent. GS1 Description: Code assigned by the supplier or supplier's agent.
92	Assigned by buyer or buyer's agent Codes assigned by a buyer or buyer's agent.
112	US, U.S. Census Bureau The Bureau of the Census of the U.S. Dept. of Commerce.
113	GS1 US Organisation responsible for GS1 System in the USA.
116	US, ANSI ASC X12 American National Standards Institute ASC X12.
131	DE, German Bankers Association German Bankers' Association.
136	GS1 UK Organisation responsible for GS1 System in the UK.
137	AT, Verband oesterreichischer Banken und Bankiers Austrian bankers association.
174	DE, DIN (Deutsches Institut fuer Normung) German standardization institute.
182	US, Standard Carrier Alpha Code (Motor) Organisation maintaining the SCAC lists and transportation operating in North America.
194	AU, AQIS (Australian Quarantine and Inspection Service) Australian Quarantine and Inspection Service.

Used Codes

200	GS1 Netherlands Organisation responsible for GS1 System in the Netherlands.
245	GS1 Denmark Organisation responsible for GS1 System in Denmark.
246	GS1 Germany Organisation responsible for GS1 System in Germany. GS1 Description: German representative of International Article Numbering association (GS1).
260	Ediel Nordic forum A code to identify Ediel Nordic forum, which is an organization standardizing the use of EDI between the participants in the Nordic power market.
281	GS1 Belgium & Luxembourg Organisation responsible for GS1 System in Belgium & Luxembourg.
286	SE, TCO (Tjänstemännen Central Organisation) The Swedish Confederation of Professional Employees.
294	GS1 Austria Organisation responsible for the GS1 System in Austria.
295	AU, Therapeutic Goods Administration Austrian administration responsible for the regulation of therapeutic goods in Australia. EDIFACT
297	IT, Ufficio IVA Ufficio responsabile gestione partite IVA, Italy (Italian Institute issuing VAT registration numbers). EDIFACT
298	GS1 Spain Organisation responsible for the GS1 System in Spain.
316	GS1 Finland Organisation responsible for the GS1 system in Finland.
317	GS1 Brazil Organisation responsible for the GS1 system in Brazil.
324	GS1 Ireland Organisation responsible for the GS1 system in Ireland.
325	GS1 Russia Organisation responsible for the GS1 system in Russia.
326	GS1 Poland Organisation responsible for the GS1 system in Poland.
327	GS1 Estonia Organisation responsible for the GS1 system in Estonia.

Used Codes

376	PANTONE Color code controlling organisation
400	FAO (Food and Agriculture Organisation) Food and Agriculture Organisation of the United Nations.
403	Comite Europeen de Normalisation Comite Européen de Normalisation (CEN), European committee for standardisation. GS1 Note: Replaces GS1 Temporary Code CEN.
404	Assigned by logistics service provider Codes assigned by a logistics service provider. GS1 Note: Replaces GS1 Temporary Code X6.
CEN	Comite European de Normalisation (GS1 Temporary Code) Comite European de Normalisation. GS1 Note: Code marked for deletion. Use value 403 instead.
PMS	Pantone Matching System (GS1 Temporary Code) Pantone Matching System.
RAL	DE, Deutsches Institut fuer Guetesicherung und Kennzeichnung (GS1 Temporary Code) German Institute for Quality Assurance and Certification.
X5	IT, Ufficio IVA (GS1 Temporary Code) Ufficio responsabile gestione partite IVA, Italy (Italian Institute issuing VAT registration numbers).
X6	Assigned by logistics service provider (GS1 Temporary Code) Codes assigned by the logistics service provider. GS1 Note: Code marked for deletion. Use value 404 instead.
ZZZ	Mutually defined A code assigned within a code list to be used on an interim basis and as defined among trading partners until a precise code can be assigned to the code list.
3207	Country name code Identification of the name of the country or other geographical entity as defined in ISO 3166-1. Notes: 1. Use ISO 3166-1 two alpha country code.
AD	Andorra
AE	United Arab Emirates
AF	Afghanistan
AG	Antigua and Barbuda
AI	Anguilla

Used Codes

AL	Albania
AM	Armenia
AO	Angola
AQ	Antarctica
AR	Argentina
AS	American Samoa
AT	Austria
AU	Australia
AW	Aruba
AX	Åland Islands
AZ	Azerbaijan
BA	Bosnia and Herzegovina
BB	Barbados
BD	Bangladesh
BE	Belgium
BF	Burkina Faso
BG	Bulgaria
BH	Bahrain
BI	Burundi
BJ	Benin
BL	Saint Barthélemy
BM	Bermuda
BN	Brunei Darussalam
BO	Bolivia (Plurinational State of)
BQ	Bonaire, Sint Eustatius and Saba
BR	Brazil
BS	Bahamas
BT	Bhutan
BV	Bouvet Island
BW	Botswana
BY	Belarus
BZ	Belize
CA	Canada

Used Codes

CC	Cocos (Keeling) Islands
CD	Congo, Democratic Republic of
CF	Central African Republic
CG	Congo
CH	Switzerland
CI	Cote D'Ivoire
CK	Cook Islands
CL	Chile
CM	Cameroon
CN	China
CO	Colombia
CR	Costa Rica
CU	Cuba
CV	Cape Verde
CW	Curaçao
CX	Christmas Island
CY	Cyprus
CZ	Czechia
DE	Germany
DJ	Djibouti
DK	Denmark
DM	Dominica
DO	Dominican Republic
DZ	Algeria
EC	Ecuador
EE	Estonia
EG	Egypt
EH	Western Sahara
ER	Eritrea
ES	Spain
ET	Ethiopia
FI	Finland
FJ	Fiji

Used Codes

FK	Falkland Islands (Malvinas)
FM	Micronesia (Federated States of)
FO	Faroe Islands
FR	France
GA	Gabon
GB	United Kingdom of Great Britain and Northern Ireland
GD	Grenada
GE	Georgia
GF	French Guiana
GG	Guernsey
GH	Ghana
GI	Gibraltar
GL	Greenland
GM	Gambia
GN	Guinea
GP	Guadeloupe
GQ	Equatorial Guinea
GR	Greece
GS	South Georgia and the South Sandwich Islands
GT	Guatemala
GU	Guam
GW	Guinea-Bissau
GY	Guyana
HK	Hong Kong
HM	Heard Island and McDonald Islands
HN	Honduras
HR	Croatia
HT	Haiti
HU	Hungary
ID	Indonesia
IE	Ireland
IL	Israel
IM	Isle Of Man

Used Codes

IN	India
IO	British Indian Ocean Territory
IQ	Iraq
IR	Iran (Islamic Republic of)
IS	Iceland
IT	Italy
JE	Jersey
JM	Jamaica
JO	Jordan
JP	Japan
KE	Kenya
KG	Kyrgyzstan
KH	Cambodia
KI	Kiribati
KM	Comoros
KN	Saint Kitts and Nevis
KP	Korea (Democratic People'S Republic of)
KR	Korea, Republic of
KW	Kuwait
KY	Cayman Islands
KZ	Kazakhstan
LA	Lao People'S Democratic Republic
LB	Lebanon
LC	Saint Lucia
LI	Liechtenstein
LK	Sri Lanka
LR	Liberia
LS	Lesotho
LT	Lithuania
LU	Luxembourg
LV	Latvia
LY	Libya
MA	Morocco

Used Codes

MC	Monaco
MD	Moldova, Republic of
ME	Montenegro
MF	Saint Martin (French Part)
MG	Madagascar
MH	Marshall Islands
MK	Macedonia, the Former Yugoslav Republic of
ML	Mali
MM	Myanmar
MN	Mongolia
MO	Macao
MP	Northern Mariana Islands
MQ	Martinique
MR	Mauritania
MS	Montserrat
MT	Malta
MU	Mauritius
MV	Maldives
MW	Malawi
MX	Mexico
MY	Malaysia
MZ	Mozambique
NA	Namibia
NC	New Caledonia
NE	Niger
NF	Norfolk Island
NG	Nigeria
NI	Nicaragua
NL	Netherlands
NO	Norway
NP	Nepal
NR	Nauru
NU	Niue

Used Codes

NZ	New Zealand
OM	Oman
PA	Panama
PE	Peru
PF	French Polynesia
PG	Papua New Guinea
PH	Philippines
PK	Pakistan
PL	Poland
PM	Saint Pierre and Miquelon
PN	Pitcairn
PR	Puerto Rico
PS	Palestine, State of
PT	Portugal
PW	Palau
PY	Paraguay
QA	Qatar
RE	Reunion
RO	Romania
RS	Serbia
RU	Russian Federation
RW	Rwanda
SA	Saudi Arabia
SB	Solomon Islands
SC	Seychelles
SD	Sudan
SE	Sweden
SG	Singapore
SH	Saint Helena, Ascension and Tristan da Cunha
SI	Slovenia
SJ	Svalbard and Jan Mayen
SK	Slovakia
SL	Sierra Leone

Used Codes

SM	San Marino
SN	Senegal
SO	Somalia
SR	Suriname
SS	South Sudan
ST	Sao Tome and Principe
SV	El Salvador
SX	Sint Maarten (Dutch part)
SY	Syrian Arab Republic
SZ	Swaziland
TC	Turks and Caicos Islands
TD	Chad
TF	French Southern Territories
TG	Togo
TH	Thailand
TJ	Tajikistan
TK	Tokelau
TL	Timor-Leste
TM	Turkmenistan
TN	Tunisia
TO	Tonga
TR	Turkey
TT	Trinidad and Tobago
TV	Tuvalu
TW	Taiwan, Province of China
TZ	Tanzania, United Republic of
UA	Ukraine
UG	Uganda
UM	United States Minor Outlying Islands
US	United States of America
UY	Uruguay
UZ	Uzbekistan
VA	Holy See

Used Codes

VC	Saint Vincent and the Grenadines
VE	Venezuela (Bolivarian Republic of)
VG	Virgin Islands, British
VI	Virgin Islands, U.S.
VN	Viet Nam
VU	Vanuatu
WF	Wallis and Futuna
WS	Samoa
YE	Yemen
YT	Mayotte
ZA	South Africa
ZM	Zambia
ZW	Zimbabwe

3453

Language name code
Code specifying the language name.

Notes:

1. Use ISO 639-1988.

AA	Afar
aa	Afar
AB	Abkhazian
ab	Abkhazian
AE	Avestan
ae	Avestan
AF	Afrikaans
af	Afrikaans
AK	Akan
ak	Akan
AM	Amharic
am	Amharic
AN	Aragonese
an	Aragonese
AR	Arabic
ar	Arabic

Used Codes

AS	Assamese
as	Assamese
AV	Avaric
av	Avaric
AY	Aymara
ay	Aymara
AZ	Azerbaijani
az	Azerbaijani
BA	Bashkir
ba	Bashkir
BE	Belarusian
be	Belarusian
BG	Bulgarian
bg	Bulgarian
BH	Bihari
bh	Bihari
BI	Bislama
bi	Bislama
BM	Bambara
bm	Bambara
BN	Bengali
bn	Bengali
BO	Tibetan
bo	Tibetan
BR	Breton
br	Breton
BS	Bosnian
bs	Bosnian
CA	Catalan; Valencian
ca	Catalan; Valencian
CE	Chechen
ce	Chechen
CH	Chamorro

Used Codes

ch	Chamorro
CO	Corsican
co	Corsican
CR	Cree
cr	Cree
CS	Czech
cs	Czech
CU	Church Slavonic; Old Slavonic; Church Slavonic; Old Bulgarian; Old Church Slavonic
cu	Church Slavonic; Old Slavonic; Church Slavonic; Old Bulgarian; Old Church Slavonic
CV	Chuvash
cv	Chuvash
CY	Welsh
cy	Welsh
DA	Danish
da	Danish
DE	German
de	German
DV	Divehi; Dhivehi; Maldivian
dv	Divehi; Dhivehi; Maldivian
DZ	Dzongkha
dz	Dzongkha
EE	Ewe
ee	Ewe
EL	Greek; Modern (1453-)
el	Greek; Modern (1453-)
EN	English
en	English
EO	Esperanto
eo	Esperanto
ES	Spanish; Castilian
es	Spanish; Castilian
ET	Estonian

Used Codes

et	Estonian
EU	Basque
eu	Basque
FA	Persian
fa	Persian
FF	Fulah
ff	Fulah
FI	Finnish
fi	Finnish
FJ	Fijian
fj	Fijian
FO	Faroese
fo	Faroese
FR	French
fr	French
FY	Western Frisian
fy	Western Frisian
GA	Irish
ga	Irish
GD	Gaelic; Scottish Gaelic
gd	Gaelic; Scottish Gaelic
GL	Galician
gl	Galician
GN	Guarani
gn	Guarani
GU	Gujarati
gu	Gujarati
GV	Manx
gv	Manx
HA	Hausa
ha	Hausa
HE	Hebrew
he	Hebrew

Used Codes

HI	Hindi
hi	Hindi
HO	Hiri Motu
ho	Hiri Motu
HR	Croatian
hr	Croatian
HT	Haitian; Haitian Creole
ht	Haitian; Haitian Creole
HU	Hungarian
hu	Hungarian
HY	Armenian
hy	Armenian
HZ	Herero
hz	Herero
IA	Interlingua (International Auxiliary Language Association)
ia	Interlingua (International Auxiliary Language Association)
ID	Indonesian
id	Indonesian
IE	Interlingue
ie	Interlingue
IG	Igbo
ig	Igbo
II	Sichuan Yi
ii	Sichuan Yi
IK	Inupiaq
ik	Inupiaq
IO	Ido
io	Ido
IS	Icelandic
is	Icelandic
IT	Italian
it	Italian
IU	Inuktitut

Used Codes

iu	Inuktiut
JA	Japanese
ja	Japanese
JV	Javanese
jv	Javanese
KA	Georgian
ka	Georgian
KG	Kongo
kg	Kongo
KI	Kikuyu; Gikuyu
ki	Kikuyu; Gikuyu
KJ	Kuanyama; Kwanyama
kj	Kuanyama; Kwanyama
KK	Kazakh
kk	Kazakh
KL	Kalaallisut; Greenlandic
kl	Kalaallisut; Greenlandic
KM	Central Khmer
km	Central Khmer
KN	Kannada
kn	Kannada
KO	Korean
ko	Korean
KR	Kanuri
kr	Kanuri
KS	Kashmiri
ks	Kashmiri
KU	Kurdish
ku	Kurdish
KV	Komi
kv	Komi
KW	Cornish
kw	Cornish

Used Codes

KY	Kirghiz; Kyrgyz
ky	Kirghiz; Kyrgyz
LA	Latin
la	Latin
LB	Luxembourgish; Letzeburgesch
lb	Luxembourgish; Letzeburgesch
LG	Ganda
lg	Ganda
LI	Limburgan; Limburger; Limburgish
li	Limburgan; Limburger; Limburgish
LN	Lingala
ln	Lingala
LO	Lao
lo	Lao
LT	Lithuanian
lt	Lithuanian
LU	Luba-Katanga
lu	Luba-Katanga
LV	Latvian
lv	Latvian
MG	Malagasy
mg	Malagasy
MH	Marshallese
mh	Marshallese
MI	Maori
mi	Maori
MK	Macedonian
mk	Macedonian
ML	Malayalam
ml	Malayalam
MN	Mongolian
mn	Mongolian
MO	Moldavian; Moldovan

Used Codes

mo	Moldavian; Moldovan
MR	Marathi
mr	Marathi
MS	Malay
ms	Malay
MT	Maltese
mt	Maltese
MY	Burmese
my	Burmese
NA	Nauru
na	Nauru
NB	Bokmal Norwegian; Norwegian Bokmal
nb	Bokmal Norwegian; Norwegian Bokmal
ND	Ndebele; North; North Ndebele
nd	Ndebele; North; North Ndebele
NE	Nepali
ne	Nepali
NG	Ndonga
ng	Ndonga
NL	Dutch; Flemish
nl	Dutch; Flemish
NN	Norwegian Nynorsk; Nynorsk, Norwegian
nn	Norwegian Nynorsk; Nynorsk, Norwegian
NO	Norwegian
no	Norwegian
NR	Ndebele; South; South Ndebele
nr	Ndebele; South; South Ndebele
NV	Navajo; Navaho
nv	Navajo; Navaho
NY	Chichewa; Chewa; Nyanja
ny	Chichewa; Chewa; Nyanja
OC	Occitan (post 1500); Provencal
oc	Occitan (post 1500); Provencal

Used Codes

OJ	Ojibwa
oj	Ojibwa
OM	Oromo
om	Oromo
OR	Oriya
or	Oriya
OS	Ossetian; Ossetic
os	Ossetian; Ossetic
PA	Panjabi; Punjabi
pa	Panjabi; Punjabi
PI	Pali
pi	Pali
PL	Polish
pl	Polish
PS	Pushto; Pashto
ps	Pushto; Pashto
PT	Portuguese
pt	Portuguese
QU	Quechua
qu	Quechua
RM	Romansh
rm	Romansh
RN	Rundi
rn	Rundi
RO	Romanian
ro	Romanian
RU	Russian
ru	Russian
RW	Kinyarwanda
rw	Kinyarwanda
SA	Sanskrit
sa	Sanskrit
SC	Sardinian

Used Codes

sc	Sardinian
SD	Sindhi
sd	Sindhi
SE	Northern Sami
se	Northern Sami
SG	Sango
sg	Sango
SI	Sinhala; Sinhalese
si	Sinhala; Sinhalese
SK	Slovak
sk	Slovak
SL	Slovenian
sl	Slovenian
SM	Samoan
sm	Samoan
SN	Shona
sn	Shona
SO	Somali
so	Somali
SQ	Albanian
sq	Albanian
SR	Serbian
sr	Serbian
SS	Swati
ss	Swati
ST	Sotho, Southern
st	Sotho, Southern
SU	Sundanese
su	Sundanese
SV	Swedish
sv	Swedish
SW	Swahili
sw	Swahili

Used Codes

TA	Tamil
ta	Tamil
TE	Telugu
te	Telugu
TG	Tajik
tg	Tajik
TH	Thai
th	Thai
TI	Tigrinya
ti	Tigrinya
TK	Turkmen
tk	Turkmen
TL	Tagalog
tl	Tagalog
TN	Tswana
tn	Tswana
TO	Tonga (Tonga Islands)
to	Tonga (Tonga Islands)
TR	Turkish
tr	Turkish
TS	Tsonga
ts	Tsonga
TT	Tatar
tt	Tatar
TW	Twi
tw	Twi
TY	Tahitian
ty	Tahitian
UG	Uighur; Uyghur
ug	Uighur; Uyghur
UK	Ukrainian
uk	Ukrainian
UR	Urdu

Used Codes

ur	Urdu
UZ	Uzbek
uz	Uzbek
VE	Venda
ve	Venda
VI	Vietnamese
vi	Vietnamese
VO	Volapük
vo	Volapük
WA	Walloon
wa	Walloon
WO	Wolof
wo	Wolof
XH	Xhosa
xh	Xhosa
YI	Yiddish
yi	Yiddish
YO	Yoruba
yo	Yoruba
ZA	Zhuang; Chuang
za	Zhuang; Chuang
ZH	Chinese
zh	Chinese
ZU	Zulu
zu	Zulu

4441 Free text value code
Code specifying free form text.

78E Proof Of Delivery (GS1 Permanent Code)
The mentioned URL refers to a Proof of Delivery document.
This Code value can be used if DE 4451 of the FTX segment is ZXL.

4451 Text subject code qualifier
Code qualifying the subject of the text.

Used Codes

1E	Additional product information address (GS1 Temporary Code) Address at which additional information on the product can be found. GS1 Note: Code marked for deletion. Use value BAI instead.
2E	VAT exemption (GS1 Temporary Code) VAT exemption reason in clear text. GS1 Note: Code marked for deletion. Use value BAQ instead.
3E	Tracking URL (GS1 Temporary Code) The internet link (URL) to track the delivery of a specific package or consignment.
AAA	Goods description [7002] Plain language description of the nature of the goods sufficient to identify them at the level required for banking, Customs, statistical or transport purposes, avoiding unnecessary detail (Generic term).
AAB	Terms of payments [4276] Conditions of payment between the parties to a transaction (generic term).
AAC	Dangerous goods additional information Additional information concerning dangerous goods.
AAD	Dangerous goods, technical name Proper shipping name, supplemented as necessary with the correct technical name, by which a dangerous substance or article may be correctly identified or which is sufficiently informative to permit identification by reference to generally available literature.
AAG	Party instructions Indicates that the segment contains instructions to be passed on to the identified party.
AAI	General information The text contains general information.
AAK	Price conditions Information on the price conditions that are expected or given.
AAM	Equipment re-usage restrictions Technical or commercial reasons why a piece of equipment may not be re-used after the current transport terminates.
AAN	Handling restriction Restrictions in handling depending on the technical characteristics of the piece of equipment or on the nature of the goods.
AAO	Error description (free text) Error described by a free text.
AAR	Terms of delivery (4053) Free text of the non Incoterms terms of delivery. For Incoterms, use: 4053.

Used Codes

AAW	Letter of credit information Information pertaining to the letter of credit.
AAZ	Additional export information The text contains additional export information.
ABN	Accounting information Self explanatory. GS1 Description: Free text information regarding account.
ABO	Discrepancy information Free text or coded information to indicate a specific discrepancy.
ABU	Deferred payment termed additional Additional terms concerning deferred payment.
ACB	Additional information The text contains additional information.
ACD	Reason Reason for a request or response.
ACE	Dispute A notice, usually from buyer to seller, that something was found wrong with goods delivered or the services rendered, or with the related invoice.
ACF	Additional attribute information The text refers to information about an additional attribute not otherwise specified.
ACL	Quality Statement Code A statement on the quality of an object.
ADK	Promotion information The text contains information about a promotion.
ADL	Meter condition Description of the condition of a meter.
ADM	Meter reading information Information related to a particular reading of a meter.
ADS	Booked item information (SWIFT Code) Information pertaining to a booked item. GS1 Description: Information related to an item booked onto a financial account.
AEI	Instructions to the applicant Instructions given to the applicant.
AFF	Batch code structure A description of the structure of a batch code.

Used Codes

AFG	Product application A general description of the application of a product.
AGW	Location Description of a location.
AGZ	Marketing activities Information concerning marketing activities.
AIP	Question A free text question.
AIQ	Party information Free text information related to a party.
AIX	Warranty terms Text describing the terms of warranty which apply to a product or service.
ALL	All documents The note implies to all documents.
BAI	Additional product information address Address at which additional information on the product can be found. GS1 Note: Replaces GS1 Temporary Code 1E.
BAJ	Information to be printed on despatch advice Specification of free text information which is to be printed on a despatch advice. GS1 Note: Replaces GS1 Temporary Code DSI.
BAK	Missing goods remarks Remarks concerning missing goods. GS1 Note: Replaces GS1 Temporary Code MIS.
BAL	Non-acceptance information Information related to the non-acceptance of an order, goods or a consignment. GS1 Note: Replaces GS1 Temporary Code NAI.
BAM	Returns information Information related to the return of items. GS1 Note: Replaces GS1 Temporary Code RTI.
BAN	Sub-line item Note contains information related to sub-line item data. GS1 Note: Replaces GS1 Temporary Code SID.
BAO	Test information Information of a test. GS1 Note: Replaces GS1 Temporary Code TIN.
BAP	External link The external link to a digital document (e.g.: URL) GS1 Note: Replaces GS1 Temporary Code ZXL.

Used Codes

BAQ	VAT exemption reason The reason for Value Added Tax exemption. GS1 Note: Replaces GS1 Temporary Code 2E.
BLR	Transport document remarks Remarks concerning the complete consignment to be printed on the bill of lading.
BLV	B2C marketing information, short description Consumer marketing information, short description.
BLW	B2B marketing information, long description Trading partner marketing information, long description.
BLX	B2C marketing information, long description Consumer marketing information, long description.
BLY	Product ingredients Information on the ingredient make up of the product. Information on the constituent ingredient make up of the product specified as one string. Example: FTX+ING+1+ +Tomato puree (54%), water, onions (9%), sunflower seed oil' FTX+ING+1+ +(cold pressed, untempered, unrefined) (10%), corn syrup (2%), soy protein (12%):++EN'
CHG	Change information Note contains change information.
CIP	Customs clearance instruction import Any coded or clear instruction agreed by customer and carrier regarding the import declaration of the goods.
CLR	Loading remarks Instructions concerning the loading of the container.
CUS	Customs declaration information Note contains customs declaration information.
DAR	Damage remarks Remarks concerning damage on the cargo.
DEL	Delivery information Information about delivery.
DIN	Delivery instructions Instructions regarding the delivery of the cargo.
DSI	Information to be printed on despatch advice (GS1 Temporary Code) Specification of free text information which is to be printed on a despatch advice. GS1 Note: Code marked for deletion. Use value BAJ instead.

Used Codes

DUT	Duty declaration The text contains a statement constituting a duty declaration.
GEN	Entire transaction set Note is general in nature, applies to entire transaction segment.
HAN	Handling instructions [4078] Instructions on how specified goods, packages or containers should be handled.
HAZ	Hazard information Information pertaining to a hazard.
IIN	Insurance instructions Instructions regarding the cargo insurance.
INS	Insurance information Specific note contains insurance information.
INV	Invoice instruction Note contains invoice instructions.
ITS	Testing instructions Instructions regarding the testing that is required to be carried out on the items in the transaction.
LIN	Line item Note contains line item information.
LOI	Loading instruction Instructions where specified packages or containers are to be loaded on a means of transport.
MIS	Missing goods remarks (GS1 Temporary Code) Remarks concerning missing goods. GS1 Note: Code marked for deletion. Use value BAK instead.
MKS	Additional marks/numbers information Additional information regarding the marks and numbers.
NAI	Non-acceptance information (GS1 Temporary Code) Information related to the non-acceptance of an order, goods or a consignment. GS1 Note: Code marked for deletion. Use value BAL instead.
ORI	Order instruction Free text contains order instructions.
OSI	Other service information General information created by the sender of general or specific value.
PAC	Packing/marking information Information regarding the packaging and/or marking of goods.

Used Codes

PAY	Payables information Note contains payables information.
PKG	Packaging information Note contains packaging information. GS1 Description: Note contains packaging instructions.
PMD	Payment detail/remittance information The free text contains payment details.
PMT	Payment information Note contains payments information.
PRD	Product information The text contains product information.
PRF	Price calculation formula Additional information regarding the price formula used for calculating the item price.
PRI	Priority information Note contains priority information.
PUR	Purchasing information Note contains purchasing information.
QQD	Quality demands/requirements Specification of the quality/performance expectations or standards to which the items must conform.
QUT	Quotation instruction/information Note contains quotation information.
REG	Regulatory information The free text contains information for regulatory authority.
RET	Return to origin information Free text information on an IATA Air Waybill to indicate consignment returned because of non delivery.
REV	Receivables The text contains receivables information.
RQR	Requested routes/routing instructions [3074] Names of places via which the consignor requests a consignment to be routed.
RQT	Tariffs and route requested [4120] Stipulation of the tariffs to be applied showing, where applicable, special-agreement numbers or references; indication of routes by frontier points or by frontier stations and, when necessary, by transit stations between.

Used Codes

RTI	Returns information (GS1 Temporary Code) Information related to the return of goods. GS1 Note: Code marked for deletion. Use value BAM instead.
SAF	Safety information The text contains safety information.
SIC	Sender's instruction to carrier [4284] Instructions given and declarations made by the sender to the carrier concerning Customs, insurance, and other formalities.
SID	Sub line item (GS1 Temporary Code) Note contains information related to sub line item data. GS1 Note: Code marked for deletion. Use value BAN instead.
SIN	Special instructions Special instructions like licence no, high value, handle with care, glass.
SPH	Special handling Note contains special handling information.
SSR	Special service request Request for a special service concerning the transport of the goods.
SUR	Supplier remarks Remarks from or for a supplier of goods or services.
TIN	Test information (GS1 Temporary Code) Information related to a test which will be, or has been, carried out. GS1 Note: Code marked for deletion. Use value BAO instead.
TRA	Transportation information General information regarding the transport of the cargo.
TXD	Tax declaration The text contains a statement constituting a tax declaration.
WHI	Warehouse instruction/information Note contains warehouse information.
XYZ	No partial delivery (GS1 Temporary Code) The goods that are not delivered have to be re-ordered by the buyer. Supplier only delivers the goods they have in stock at that moment. One order leads to one delivery.
ZXL	External link (GS1 Temporary code) The external link to a digital document (e.g.: URL) GS1 Note 1: This Code value can be used if no EFI segment is available. If the type of the referenced document (e.g. proof-of-delivery.pdf) can be identified by a code value of DE 1001, this code value should be used to fill DE 4441. (e.g. 78E), DE 3055 = 9. GS1 Note 2: Code marked for deletion. Use value BAP instead.

Used Codes

ZYZ Partial delivery allowed (GS1 Temporary Code)
 The supplier keeps delivering until the entire order is fulfilled. One order can lead to many deliveries. The buyer doesn't need to place a new order; they just waits for the other goods to be delivered.

ZZZ Mutually defined
 Note contains information mutually defined by trading partners.

4453 Free text function code
 Code specifying the function of free text.

1 Text for subsequent use
 The occurrence of this text does not affect message processing.

2 Text replacing missing code
 Text description of a coded data item for which there is no currently available code.

3 Text for immediate use
 Text must be read before actioning message.

